

LC-CABIN V2

ASSEMBLY MANUAL



Legend



Black boxes will display assembly drawings and diagrams.









Green boxes will indicate the steps to follow during the assembly process.

Light green boxes contain various notes and warnings related to the assembly steps.



Grey boxes show the references and parts required for each assembly step.

Fasteners



Image	Reference	Description
	10503-00049	Expansion bolt M10×60
	11201-00277	Screw DIN912 M8×20
	11201-00042	Screw DIN912 M5×10
	11201-00198	Screw DIN912 M6×20
	10503-00050	Nut DIN6923 M8
	11201-00075	Screw DIN912 M4×8
	11201-00196	Screw DIN7991 M6×16
	11201-00185	Screw DIN7380 M5×16

For pillar and door bases



	11201-00123	Nut DIN 934 M10 zinc-plated
	10504-00006	Washer DIN 125 M10 zinc-plated
	11201-00323	Screw DIN7991 M10×30

Parts breakdown

* Breakdown includes all possible cabin variants. Not all LC-CABIN V2 orders include all the parts listed above.







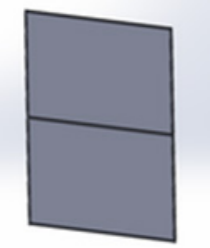

Pillar Support Assembly

Name	Part	Reference
Main pillar		10503-00032
Top pillar flange		10503-00033

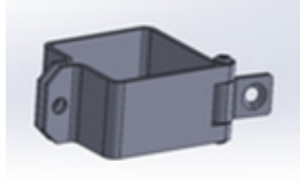
Panel 1500×2200mm

Name	Part	Reference
Panel 1500 mm wide and 2200 mm high		10501-00003

Door Module 2000×2200mm





Name	Part	Reference
Door hinge bracket assembly		10502-00007
Angle bracket for door crossbar		10502-00008
Door crossbar		10502-00009
Right hinge cover		10502-00010
Left hinge cover		10502-00011
Central door cover		10502-00012
Magnet support bracket for door		10502-00013

Parts breakdown





* Breakdown includes all possible cabin variants. Not all LC-CABIN V2 orders include all the parts listed above.

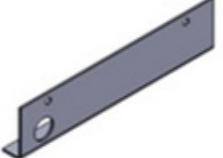

Door Module 2000×2200mm

Name	Part	Reference
Right door 1		10502-00015
Left door 2		10502-00016
Door pillar assembly A		10502-00017
Door pillar assembly B		10502-00018
Top pillar flange		10503-00033
Door foot stop support		10502-00021
Magnetic door latch		10502-00022

Electrical Panel 1000×2200mm

Name	Part	Reference
Canaleta cables panel electrico		10501-00016
Canaleta superior panel electrico		10501-00017
Canaleta cables puerta		10502-00014
Panel electrico 1 metro		10501-00018
Prensaestopa M13.5		10203-00015

Floor Base Assembly for Door

Name	Part	Reference
Cabin door floor base		10504-00004

Parts breakdown

* Breakdown includes all possible cabin variants. Not all LC-CABIN V2 orders include all the parts listed above.



Floor Base Assembly for Pillar

Name	Part	Reference
Cabin pillar floor base		10504-00008

Panel with Window – 1000×2200mm

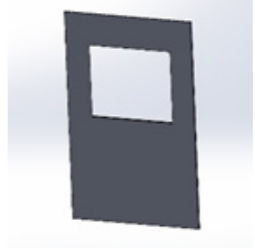
Name	Part	Reference
A3 Glass Panel, 1500 mm wide × 2200mm high		10501-00013

Corner Panel – 2200mm High

Name	Part	Reference
Corner panel 2200 mm high		10501-00005

Wall Panel – 2200mm High

Name	Part	Reference
End panel for wall closure		10501-00019

General Considerations



Before starting the assembly, it is essential to ensure that the location where the cabin will be installed has a completely level floor. This condition is fundamental to guarantee stability, proper alignment of the parts, and the correct functioning of the structure once assembled.

The assembly sequence may vary slightly depending on whether the cabin will be mounted against a wall or assembled as a standalone and fully enclosed unit.

If the cabin will be enclosed on one or more sides by a back wall, the assembly should begin precisely from that wall. This allows for a secure anchoring of the structure from the start and facilitates integration with the existing surface.

If assembling a complete cabin, the process must begin with the door panel, as this element is crucial for aligning the rest of the structure and ensuring a proper seal.

Assembly Process:

1- General Structure

2- Door

3- Closure



LC-CABIN V2 ASSEMBLY MANUAL

EXAMPLE: FULLY ASSEMBLED 3×3 CABIN



1- Left Door Pillar

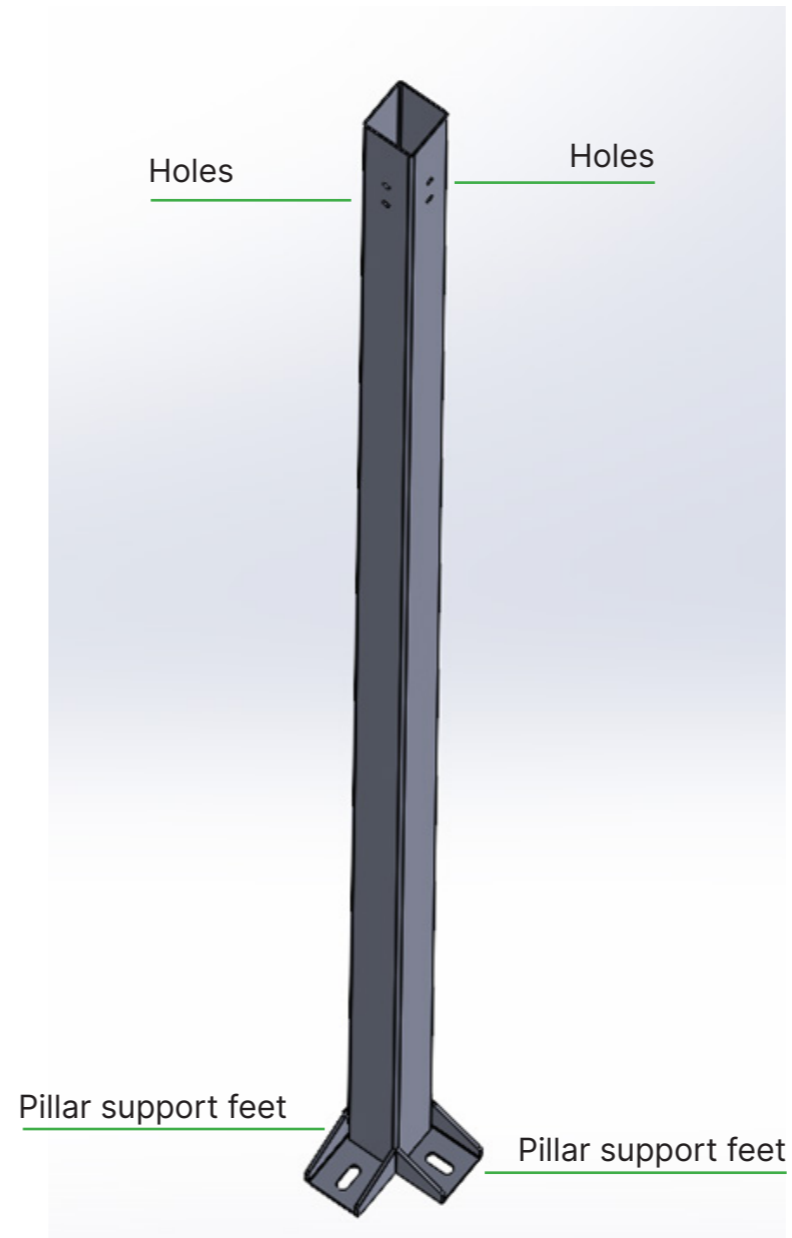
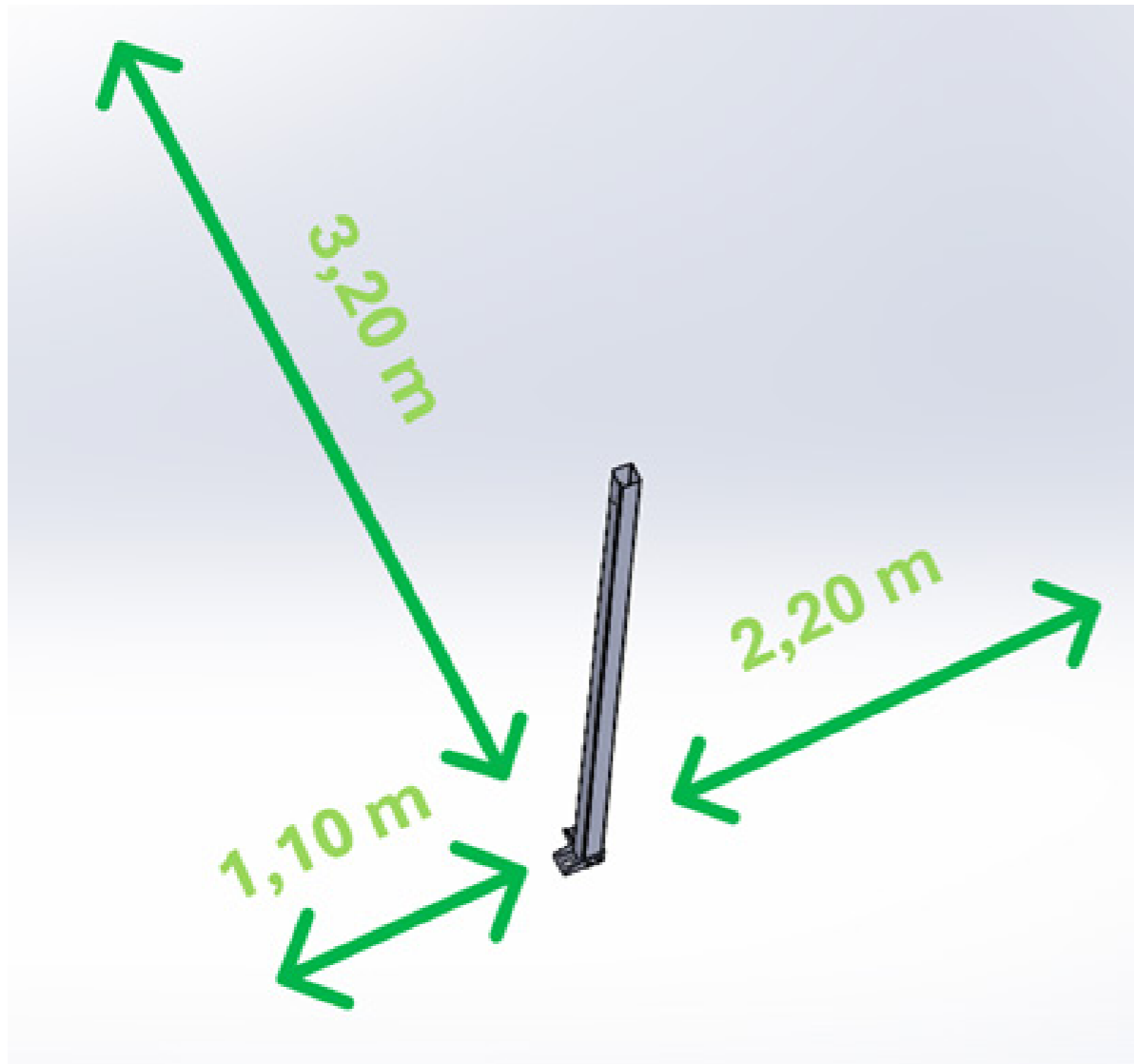

Before starting the assembly, ensure that the surface where the cabin will be installed is level, with a maximum tolerance of ± 5 mm.

Take into account the dimensions of the cabin you want to assemble (in this case it is a 3x3), to correctly position the first pillar (there must be a free space of 3.2 m at the back, 1.1 m on the left side and 2.2 m on the right side approximately).

The assembly will begin with the left door pillar. This is the pillar that has the holes on the same face where the pillar base supports are located.



10502-00018 Door pillar assembly B

2- Cabin Orientation

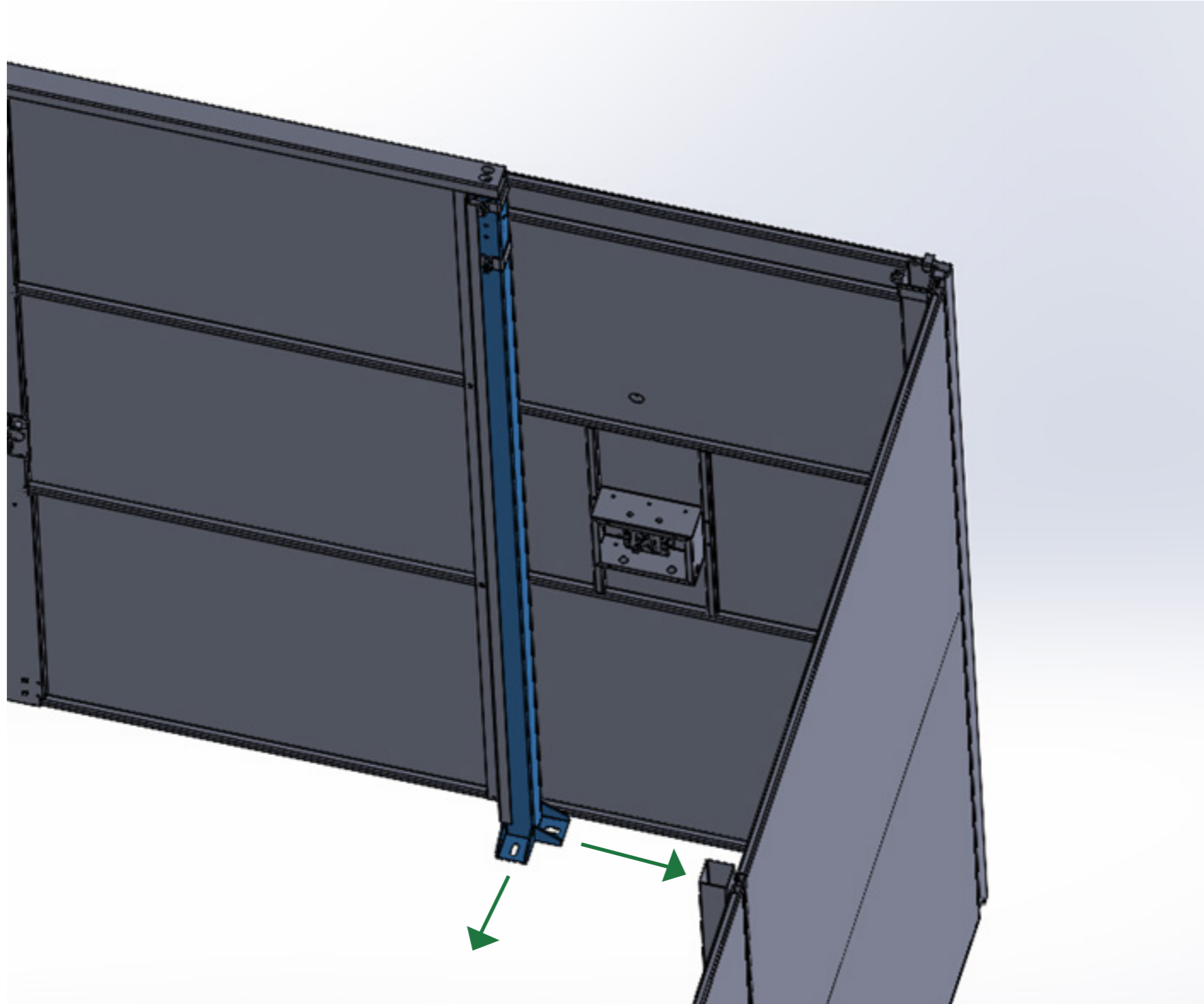

According to the intended orientation of the cabin, install the pillar with the “L”-shaped base, ensuring that the opening or direction of the base matches the one shown in the reference image.

10502-00018 Door pillar assembly B

3- Bolts and Pillar Brackets

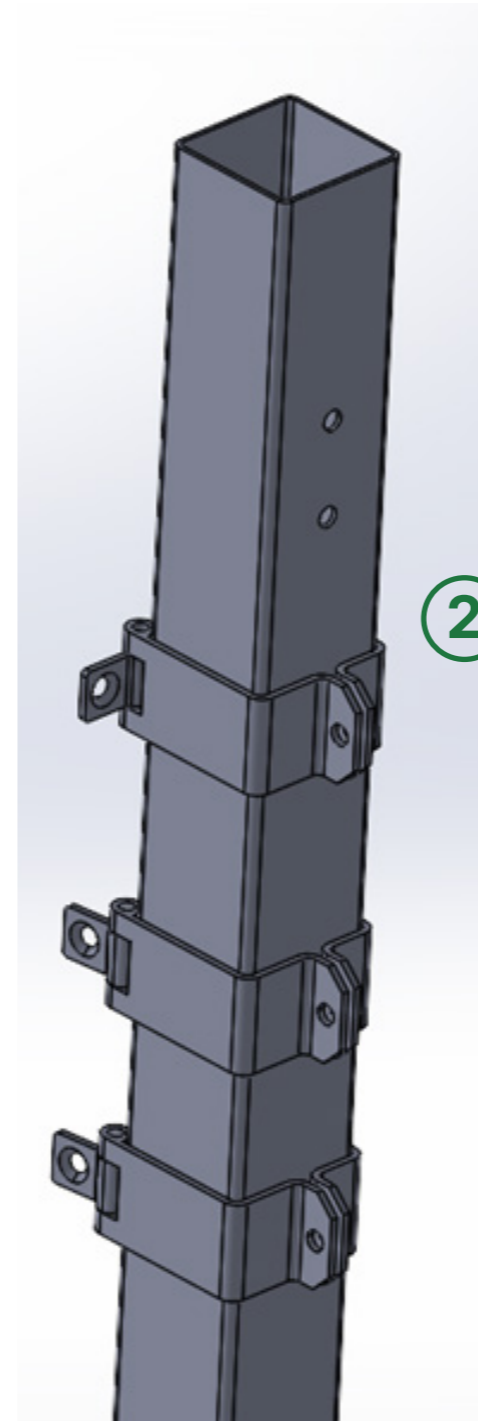
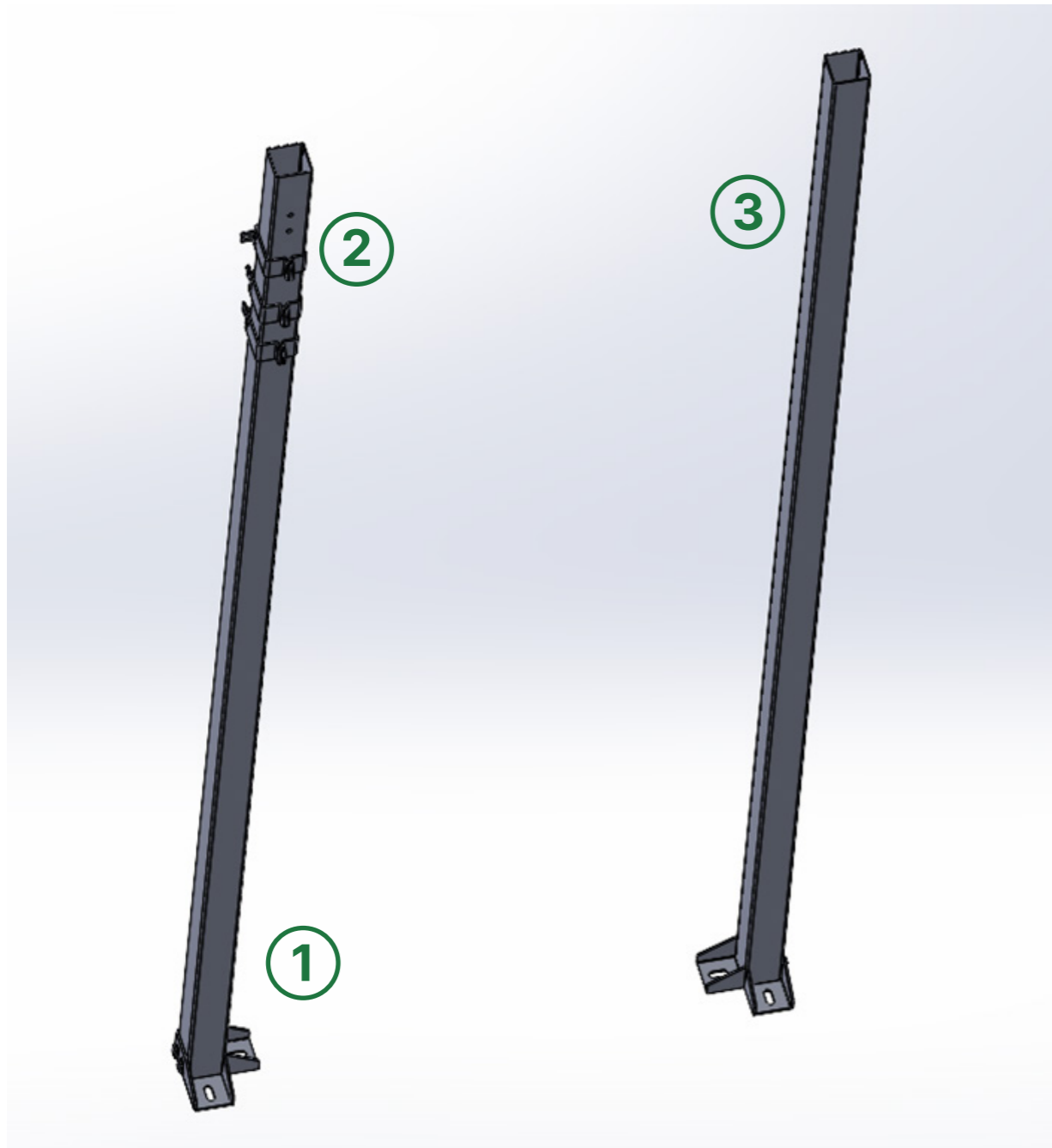

1. Once the pillar with the “L”-shaped base is correctly oriented, proceed to fix it to the floor using two M10×60 expansion bolts.

Before anchoring, drill the necessary holes in the floor according to the specified measurements for the bolts.

2. Then, insert the hinge brackets inside the post corresponding to the door pillar. The brackets must remain loose and oriented as shown in the reference image.

3. Next, place the second pillar (without anchoring it to the floor yet), positioning it so that the “L”-shaped base is oriented to form the corner of the structure.

- x2: 10503-00049_Expansion Bolt M10×60
- x3: 10502-00007_Door Hinge Bracket Assembly
- x1: 10503-00032_Main Pillar

4- Electrical Panel

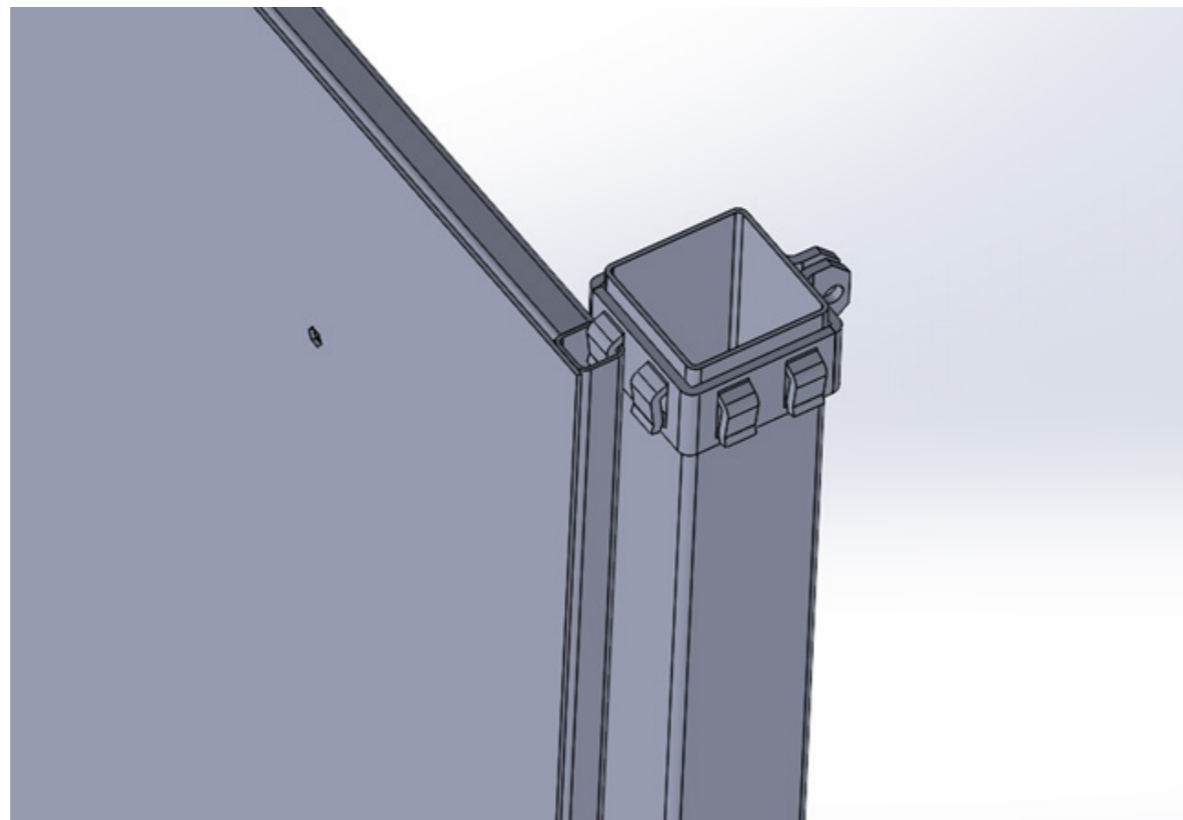
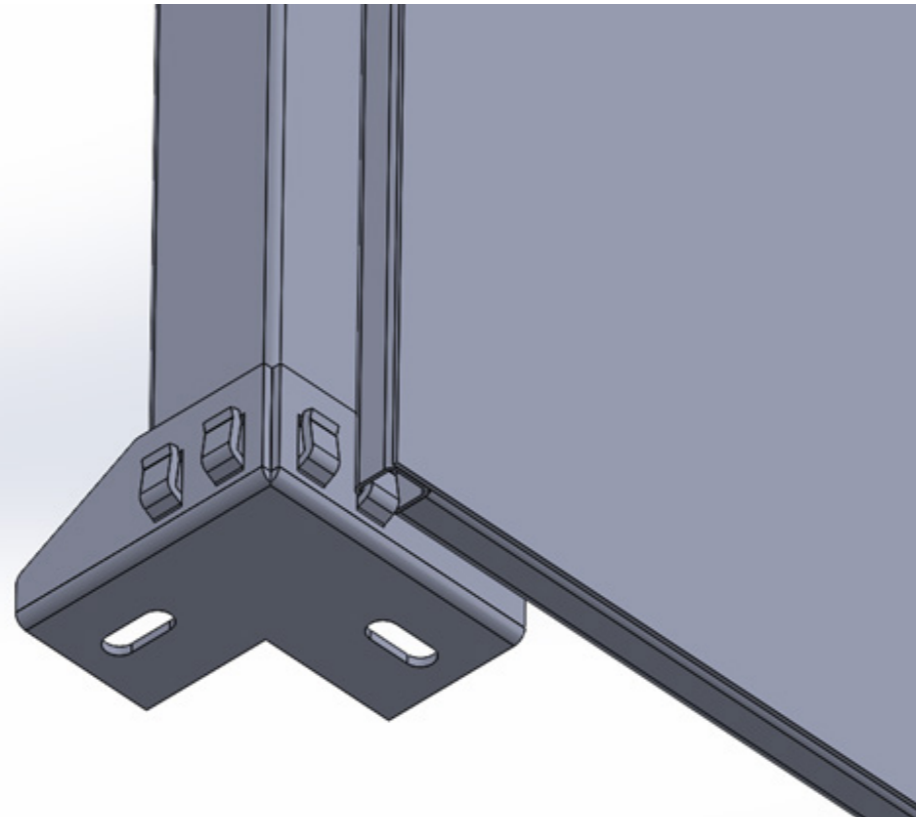

Fit the electrical panel by hooking it initially into the lower brackets of the door and corner pillars.

Once properly seated, secure the top part of the panel using the corresponding bracket on the door pillar.

Do not fully tighten the bracket yet.

- x1: 10501-00018_Electrical Panel 1 meter
- x1: 10503-00033_Top Pillar Bracket

5- Next Pillar

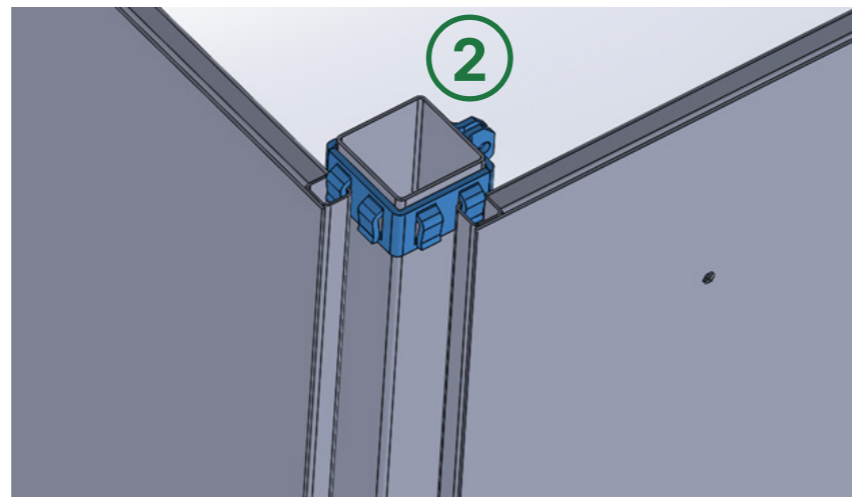
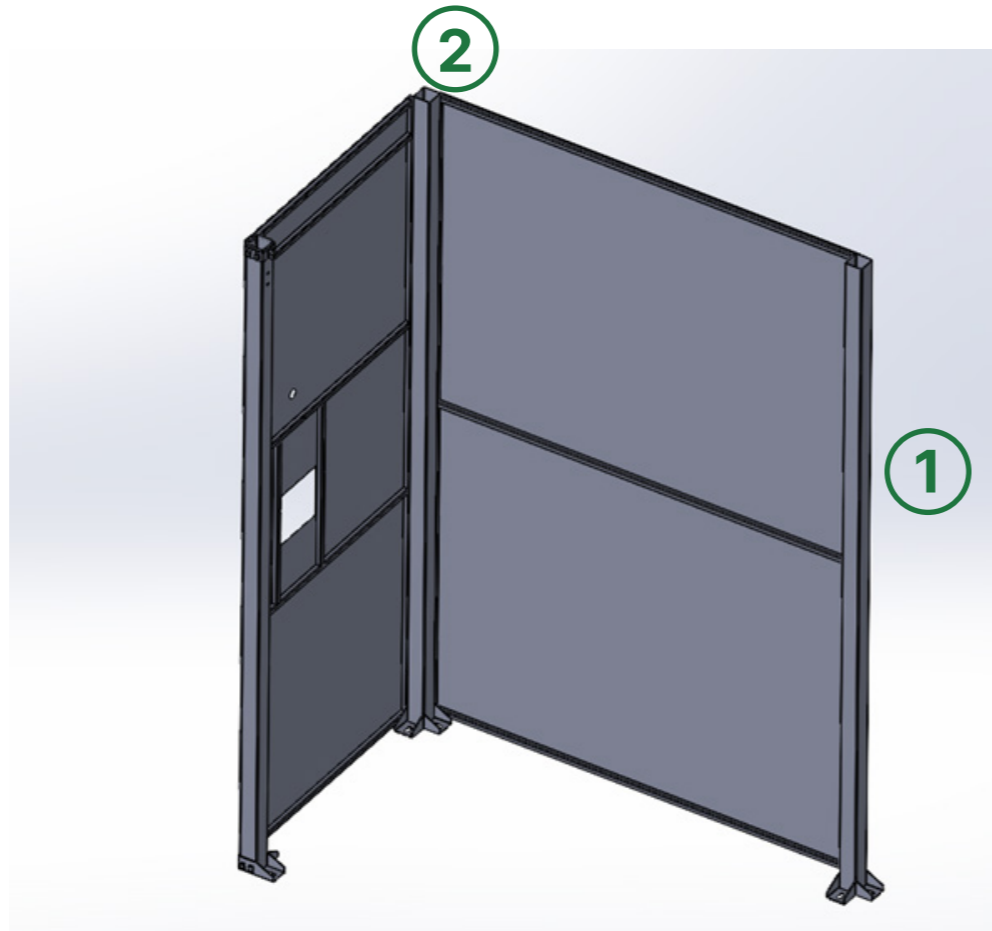

1. Install the next pillar along with the 1.5-meter panel. First insert the panel from the bottom, ensuring it is properly seated in the lower hooks or guides.
2. Then, fix the top part of the panel using the corresponding bracket on the corner pillar.

Do not anchor the pillars to the floor until the end. Only fix the left door pillar to ensure stability.

- x1: 10503-00032_Main Pillar
- x1: 10501-00003_1500 mm x 2200mm Panel
- x1: 10503-00033_Top Pillar Bracket

6- Remaining Pillars and Panels

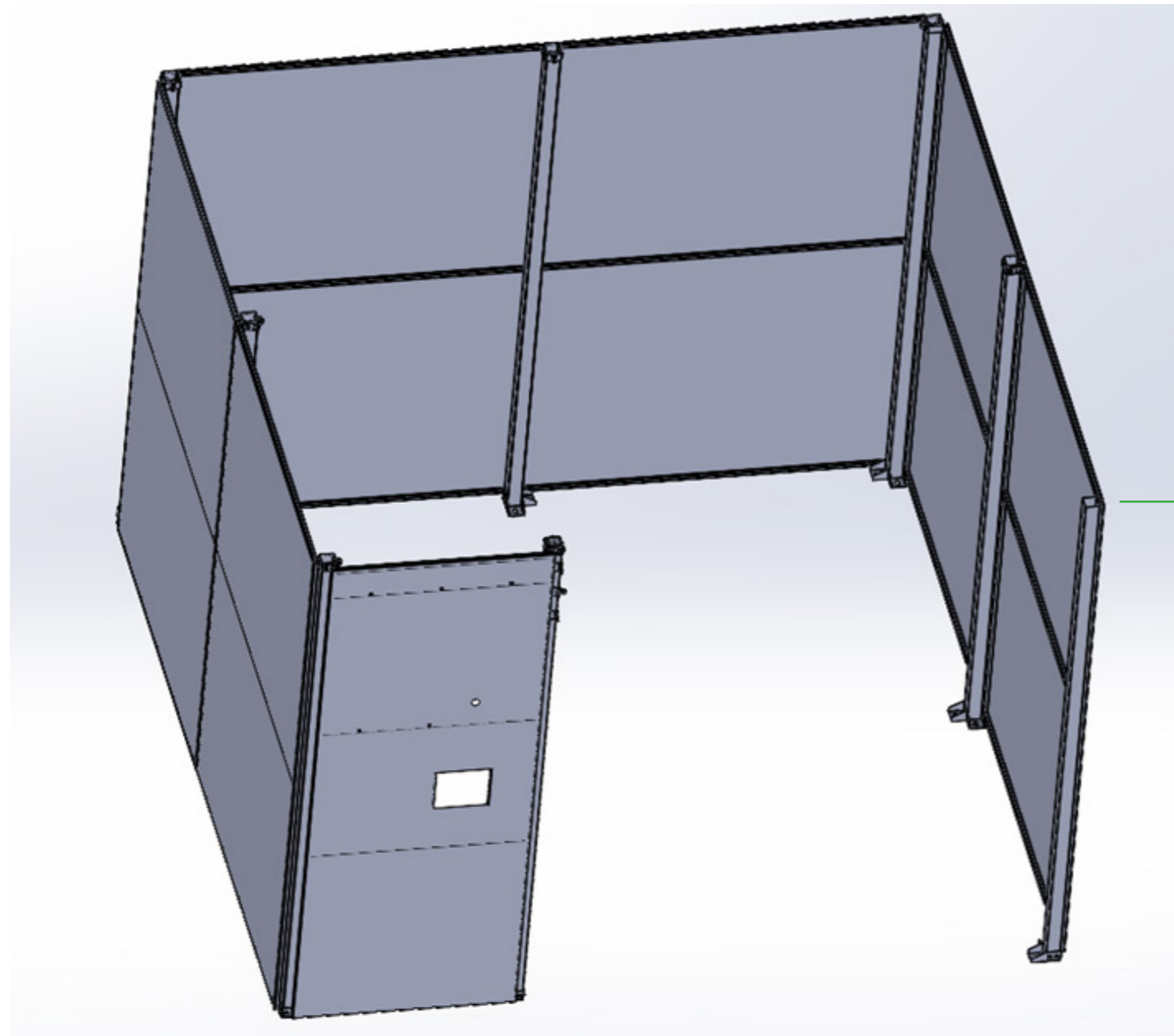

Door Pillar Holes

Continue installing the pillars and panels following the same procedure: insert the bottom of the panel into place and secure the top using brackets. Make sure to maintain proper orientation and alignment of each component throughout the process.

Finish this section by placing the pillar corresponding to the right-hand door, ensuring it is oriented to form the corner, as shown in the reference image.

The holes in the door pillar must face the outside of the cabin so that they remain visible, as shown in the image.

- x5: 10501-00003_1500 mm × 2200 mm Panel
- x5: 10503-00033_Top Pillar Bracket
- x1: 10502-00017_Door Pillar Assembly A

7- Hinge Brackets

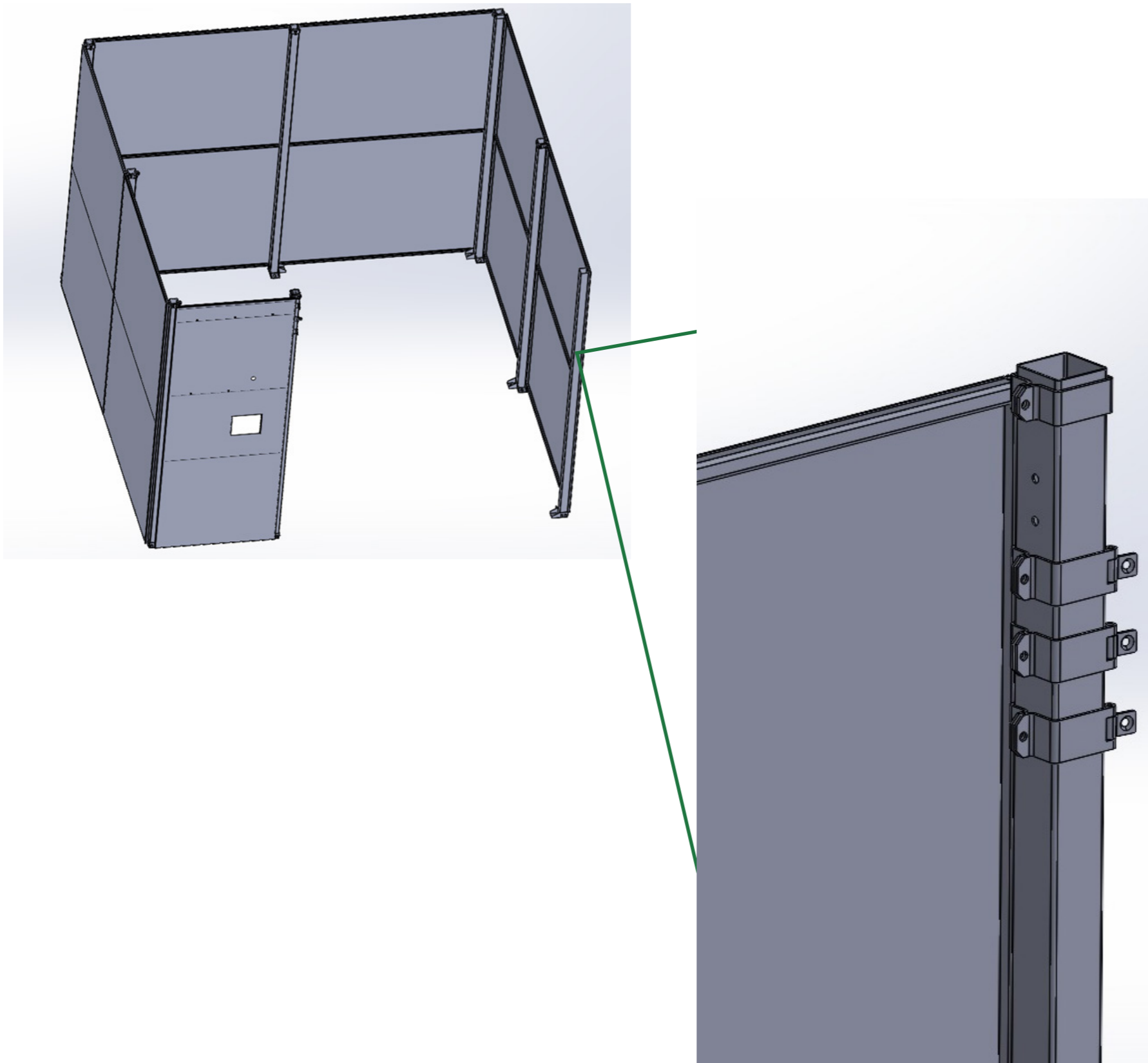

Insert the hinge brackets into the inside of the pillar corresponding to the right-hand door, making sure their orientation matches the one shown in the reference image.

Next, secure the panel using the top bracket, ensuring the fit is firm and properly aligned.

x3: 10502-00007_Door Hinge Bracket Assembly
x1: 10503-00033_Top Pillar Bracket

8- Crossbar Brackets

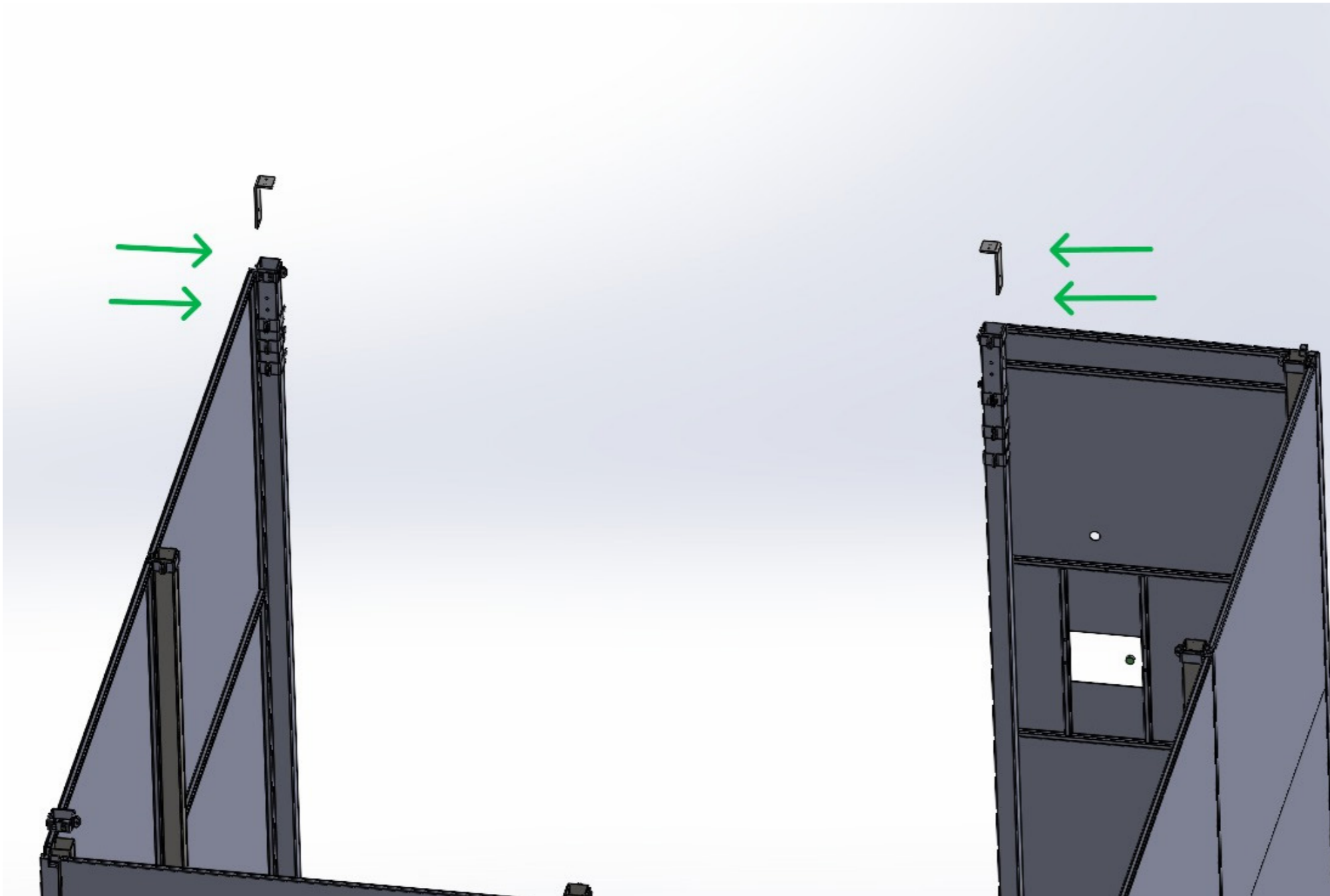

Screw the upper crossbar brackets to the left and right door pillars using M6×20 screws.

x2: 10502-00008_Door Crossbar Bracket
x4: 11201-00198_Screw DIN912 M6×20

9- Crossbar

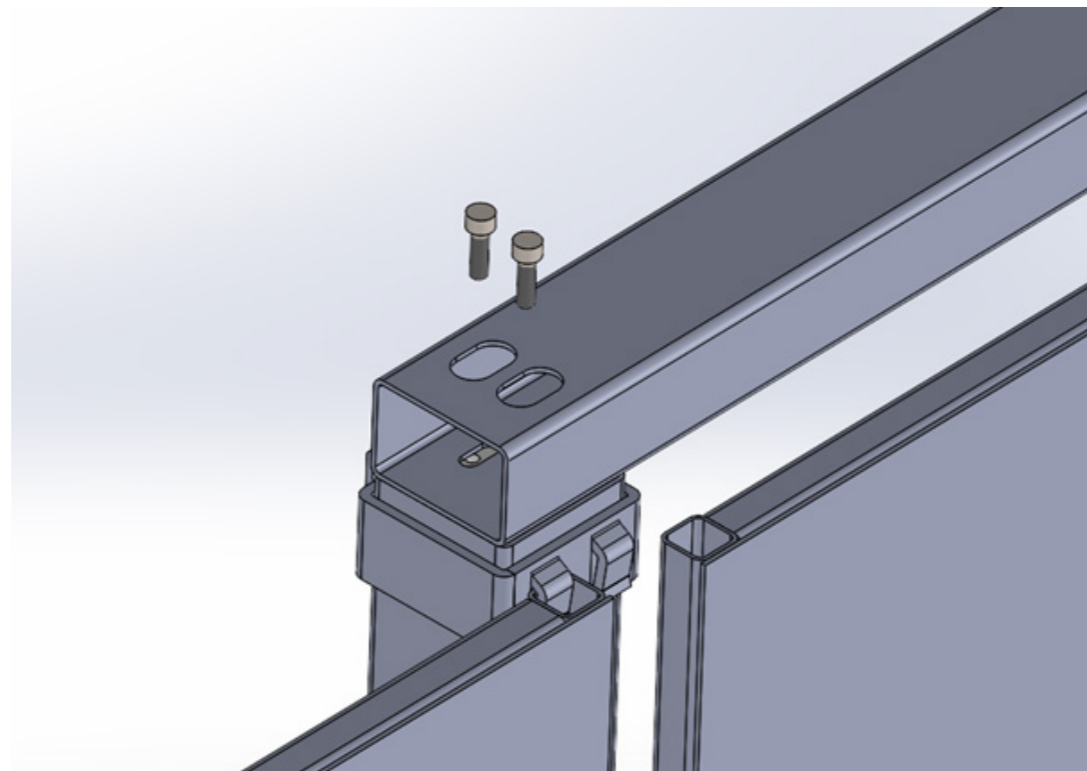
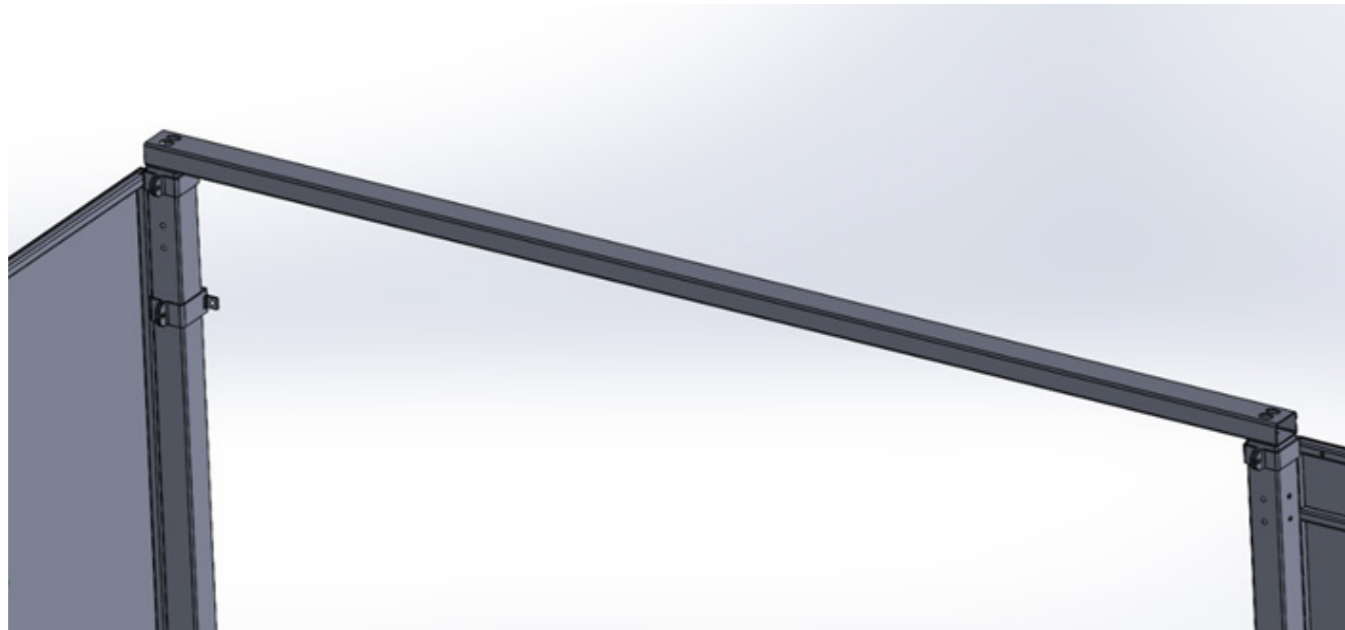

Place the door crossbar on the previously installed pillars. Align it properly and screw it to the brackets using M6×20 screws.

The correct orientation of the crossbar is with the center holes facing downward and toward the outside of the cabin.

Do not fully tighten the screws at this stage, as later adjustments will be necessary to ensure proper door alignment.

x1: 10502-00009_Door Crossbar
x4: 11201-00198_Screw DIN912 M6×20

10- Left Door

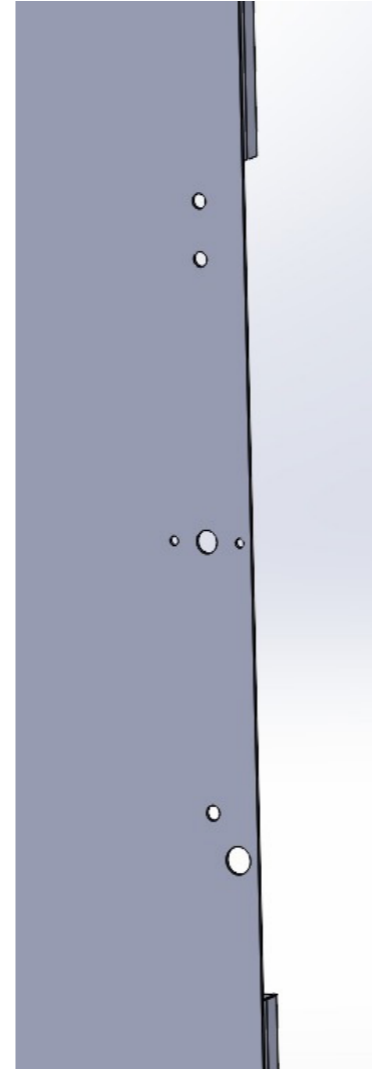
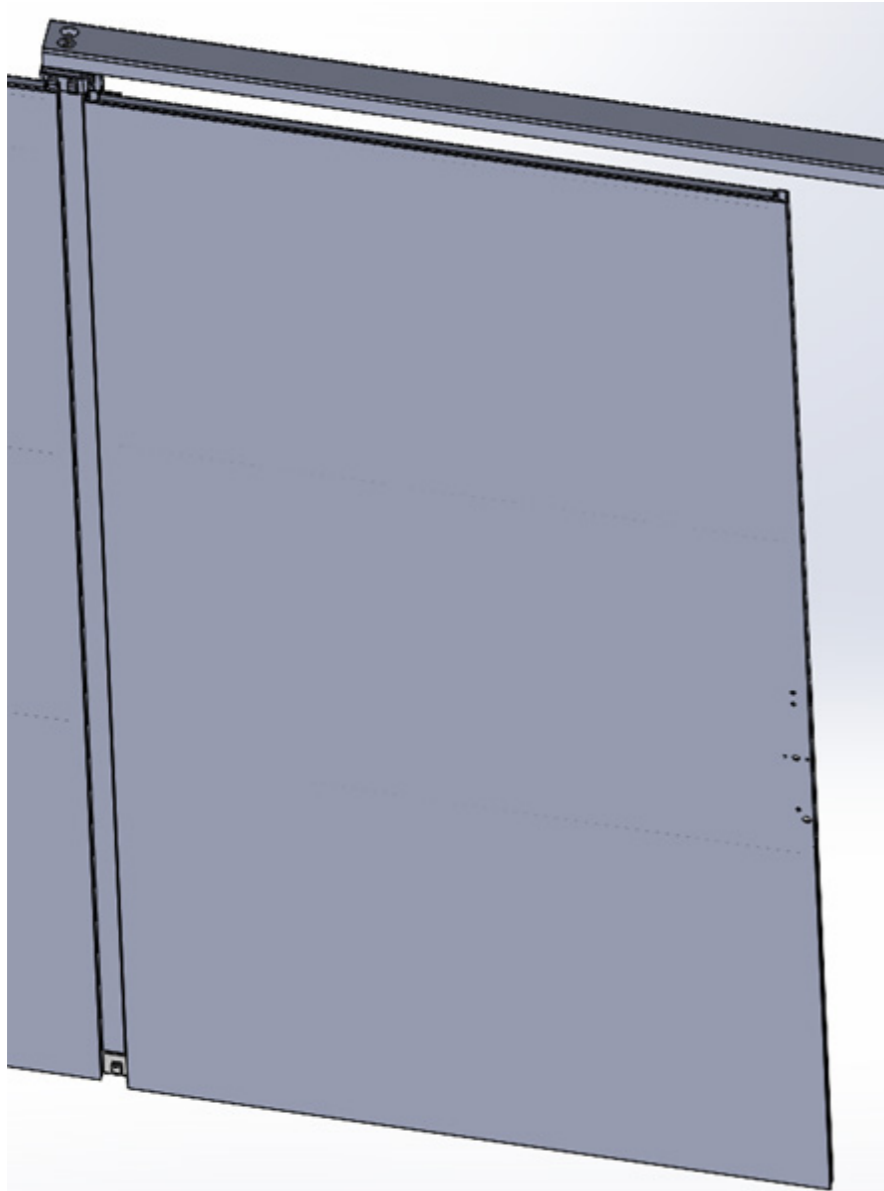

Install the left door by fastening it to the corresponding pillar using the hinge brackets. Use countersunk screws M6×16 to secure the connection.

The left door (as seen from the outside) is the one with the holes, as shown in the image. These holes should be positioned in the center area of the door.

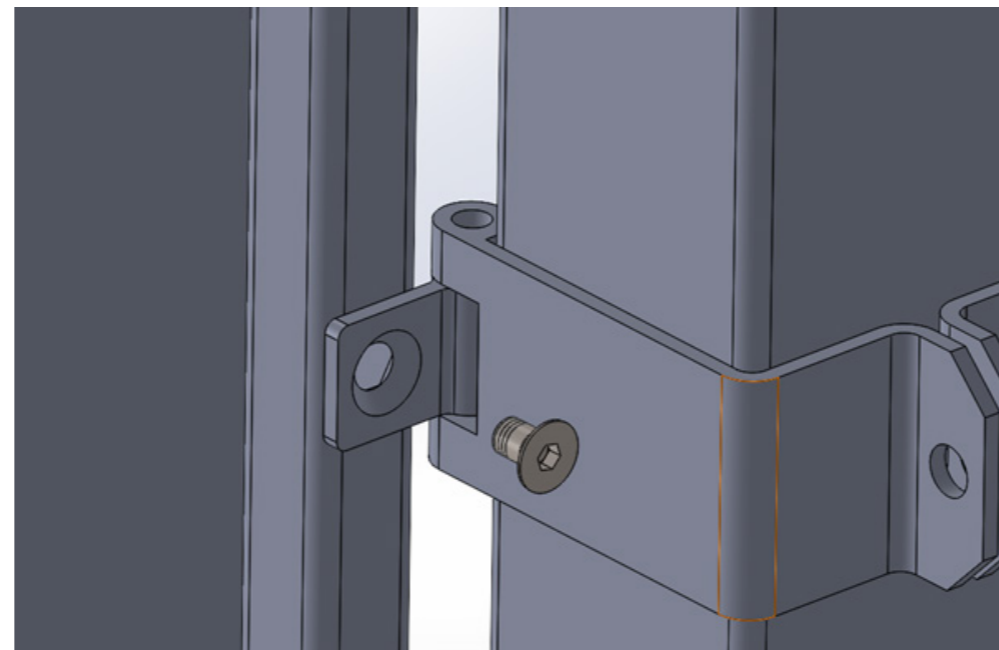
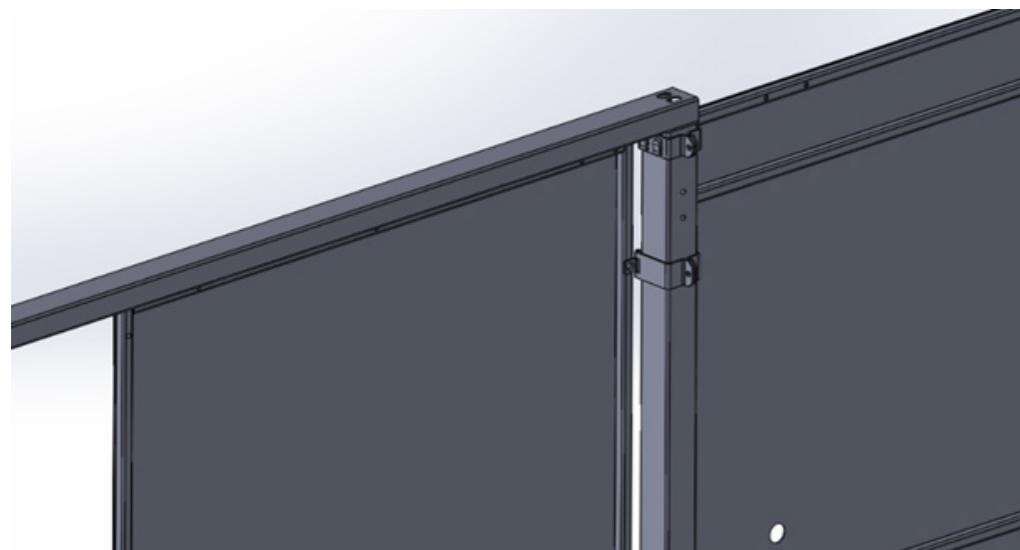

x1: 10502-00016_Left Door 2
x3: 11201-00196_Screw DIN7991 M6×16

11- Position and Screw the Door



Adjust the door to the proper height so that it can open and close freely, without hitting the floor or the upper crossbar.

Once the correct position is achieved, tighten the hinge brackets using M8×20 screws and M8 nuts, ensuring a firm and stable fastening.

x3: 11201-00277_Screw DIN912 M8×20
x3: 10503-00050_Nut DIN6923 M8

12- Right Door

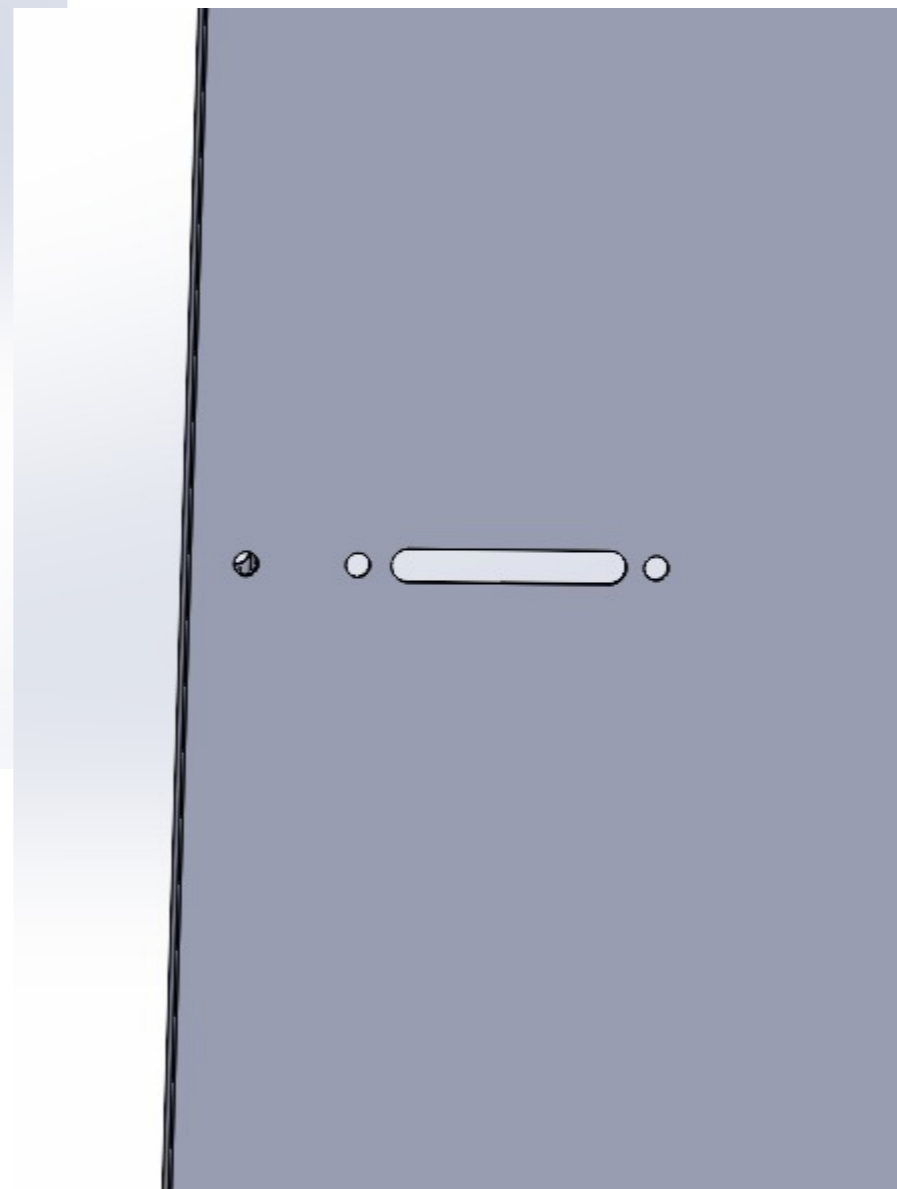
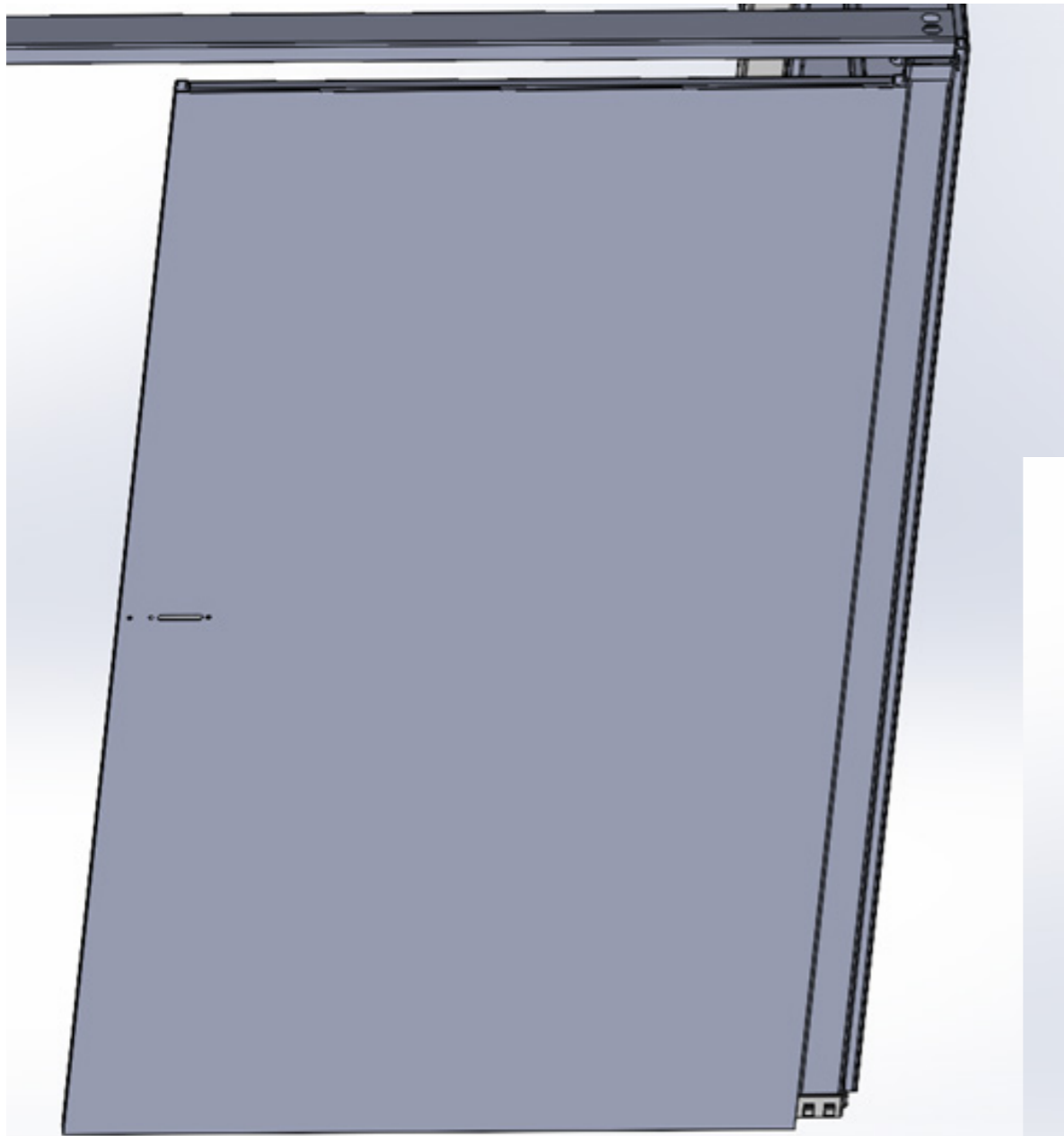

Install the right door following the same procedure as for the left door. Adjust its height so that it aligns with the left door and does not interfere with the floor when opening or closing.

Once the final position is set, tighten the hinge brackets using Allen screws M8×20 and M8 nuts, ensuring a secure and stable fastening.

The right door is the one with the elongated (slot) hole in the center, as shown in the image.

- x1: 10502-00015_Right Door 1
- x3: 11201-00277_Screw DIN912 M8×20
- x3: 10503-00050_Nut DIN6923 M8
- x3: 11201-00196_Screw DIN7991 M6×16

13- Door Spacing

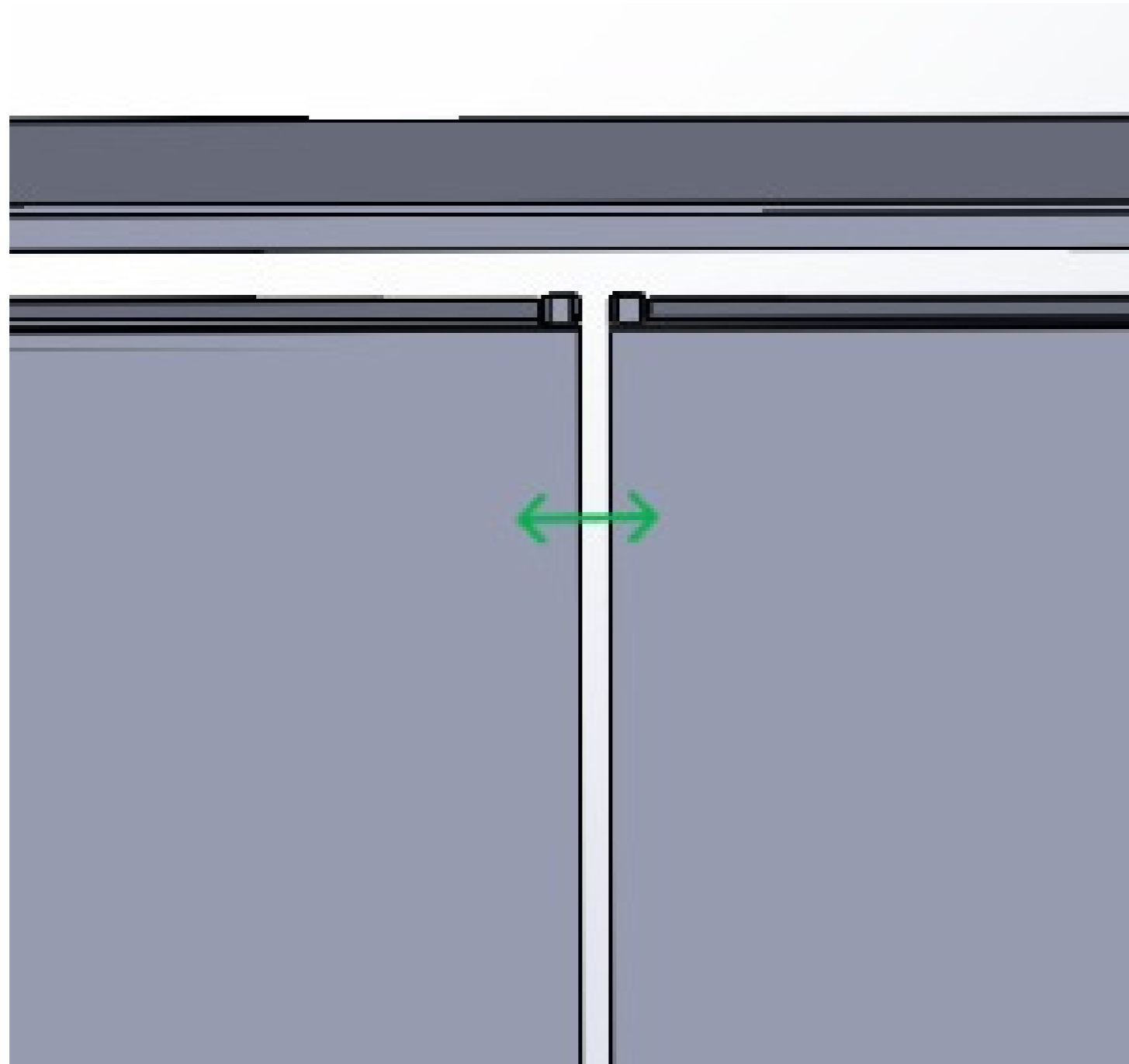

Adjust the right post by moving it outward or inward as needed until proper alignment between both doors is achieved.

When closed, the doors should not collide with each other and should maintain a uniform gap of approximately 10 mm.

Once the correct alignment is reached, tighten the upper crossbar screws to permanently secure the position.

14- Cabin Angles

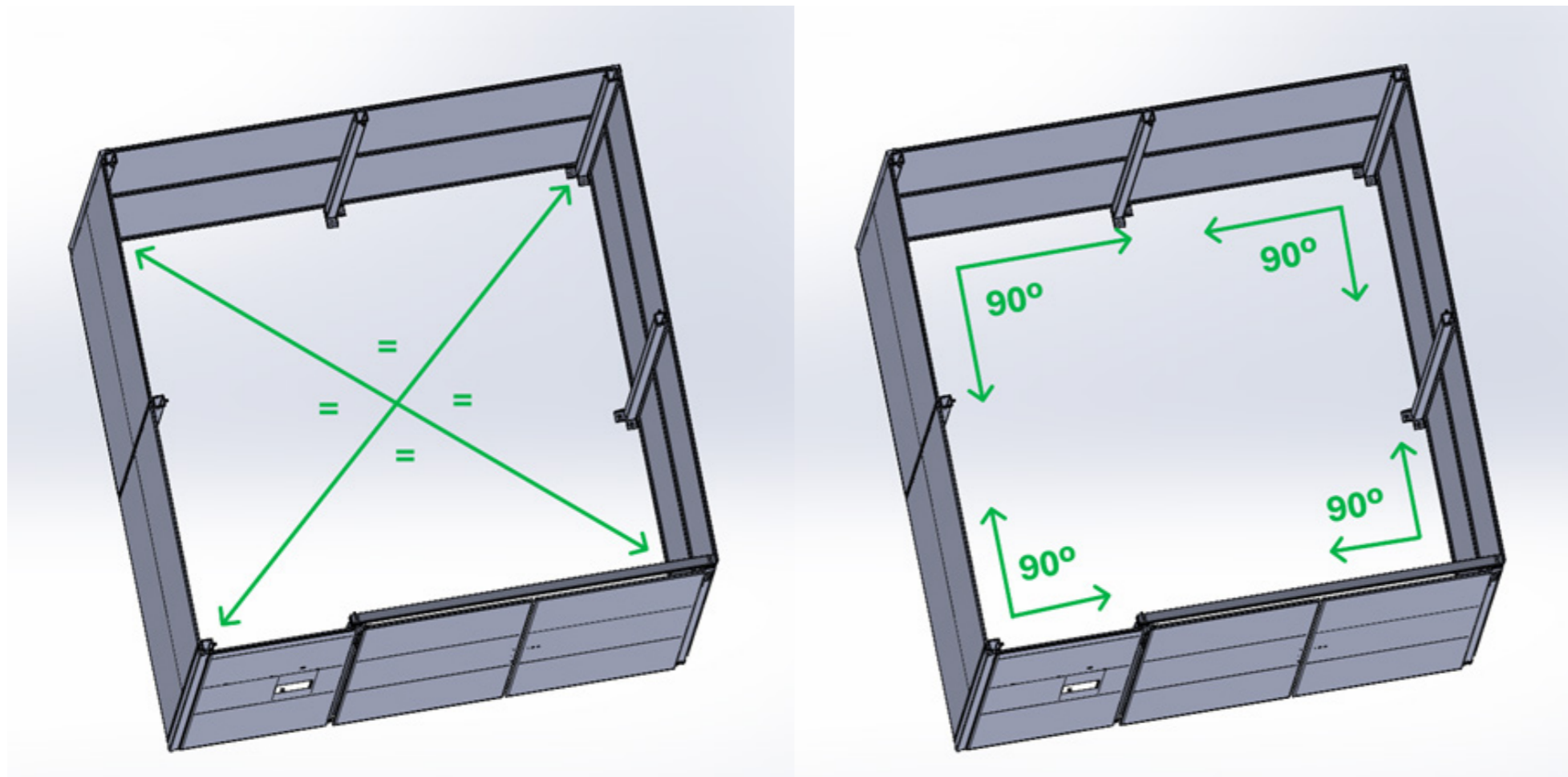

Once the perimeter of the cabin is closed, measure the distance between the pillars located at opposite corners.

Adjust the position of the pillars as needed, ensuring that the spacing between them is even. Also, verify that the angles formed between the walls at each corner are 90°, ensuring the structure is properly squared.

15- Anchoring Pillars to the Floor

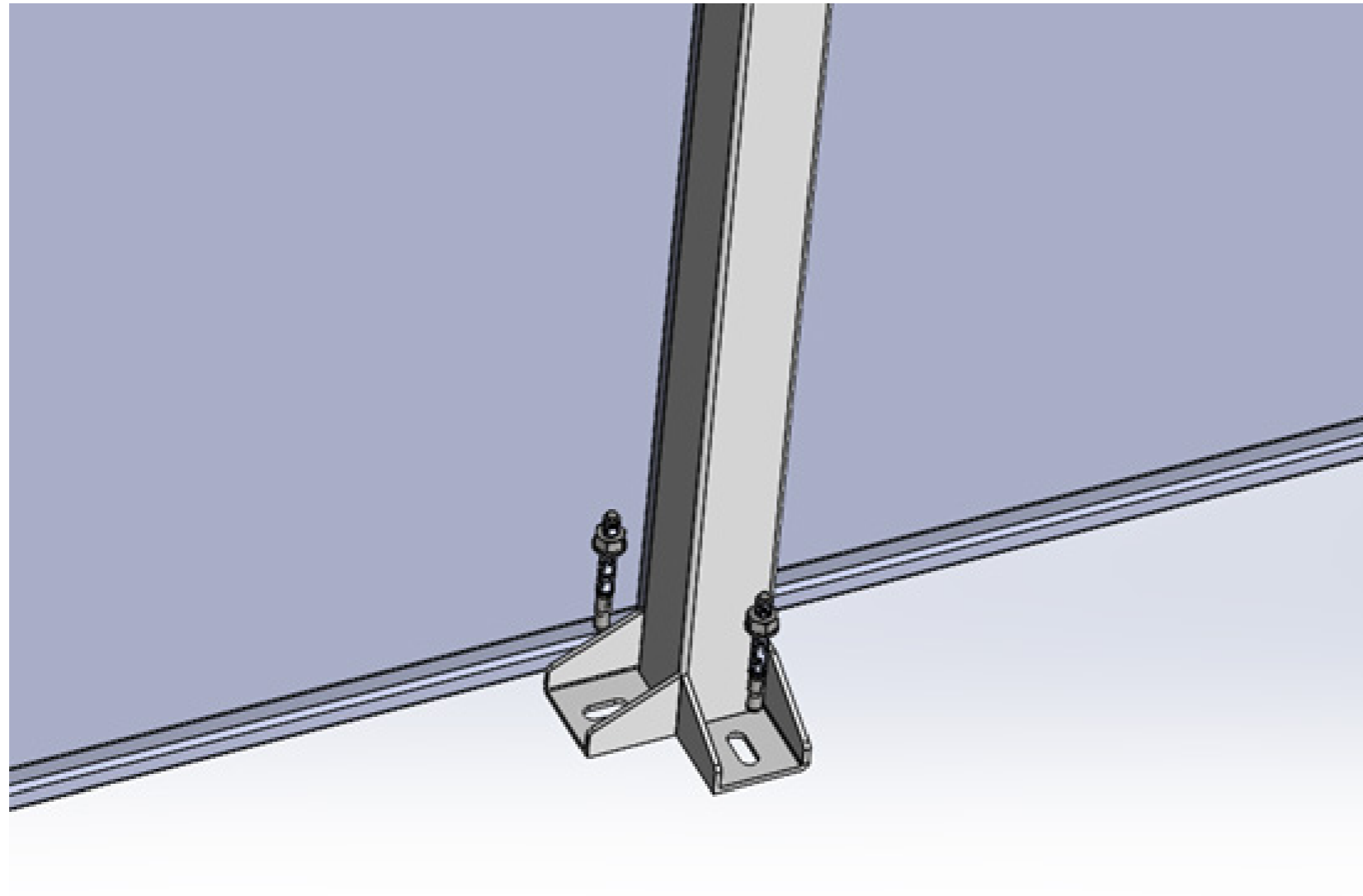

Once all perimeter alignment, leveling, and squareness checks have been completed, proceed to permanently fix all pillars to the floor.

Use two M10×60 expansion bolts per pillar, making sure each one is properly inserted into its hole and firmly anchored.

x14: 10503-00049_Expansion Bolt
M10×60

16- Corner Pillars

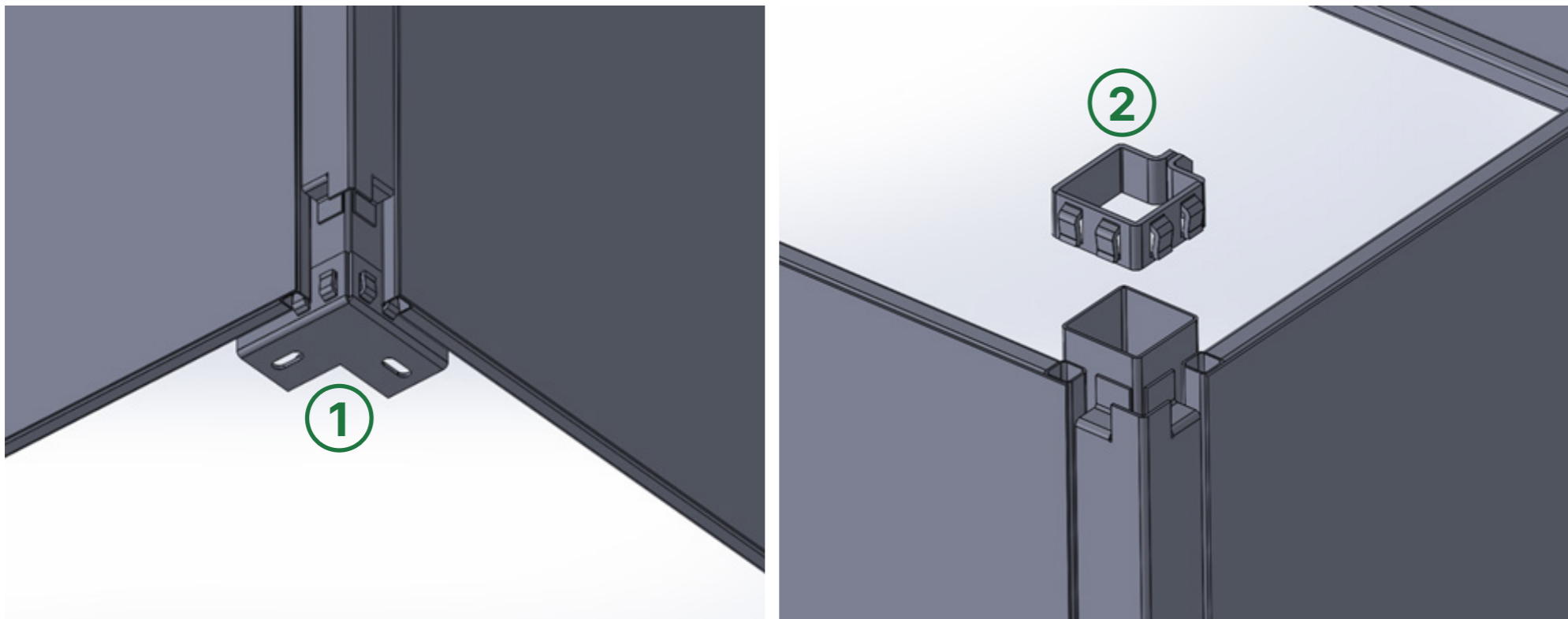

1. Install the corner panels by first inserting the bottom part into its corresponding position.
2. Then, insert the top part using the top bracket.

To complete this step correctly, it will be necessary to temporarily remove the bracket holding the adjacent panels, in order to reinsert it simultaneously along with the corner panel. Make sure all three elements (both panels and the corner panel) are securely fastened using the same bracket.

x4: 10501-00005_Corner Panel 2200 mm High

17- Screw top flanges

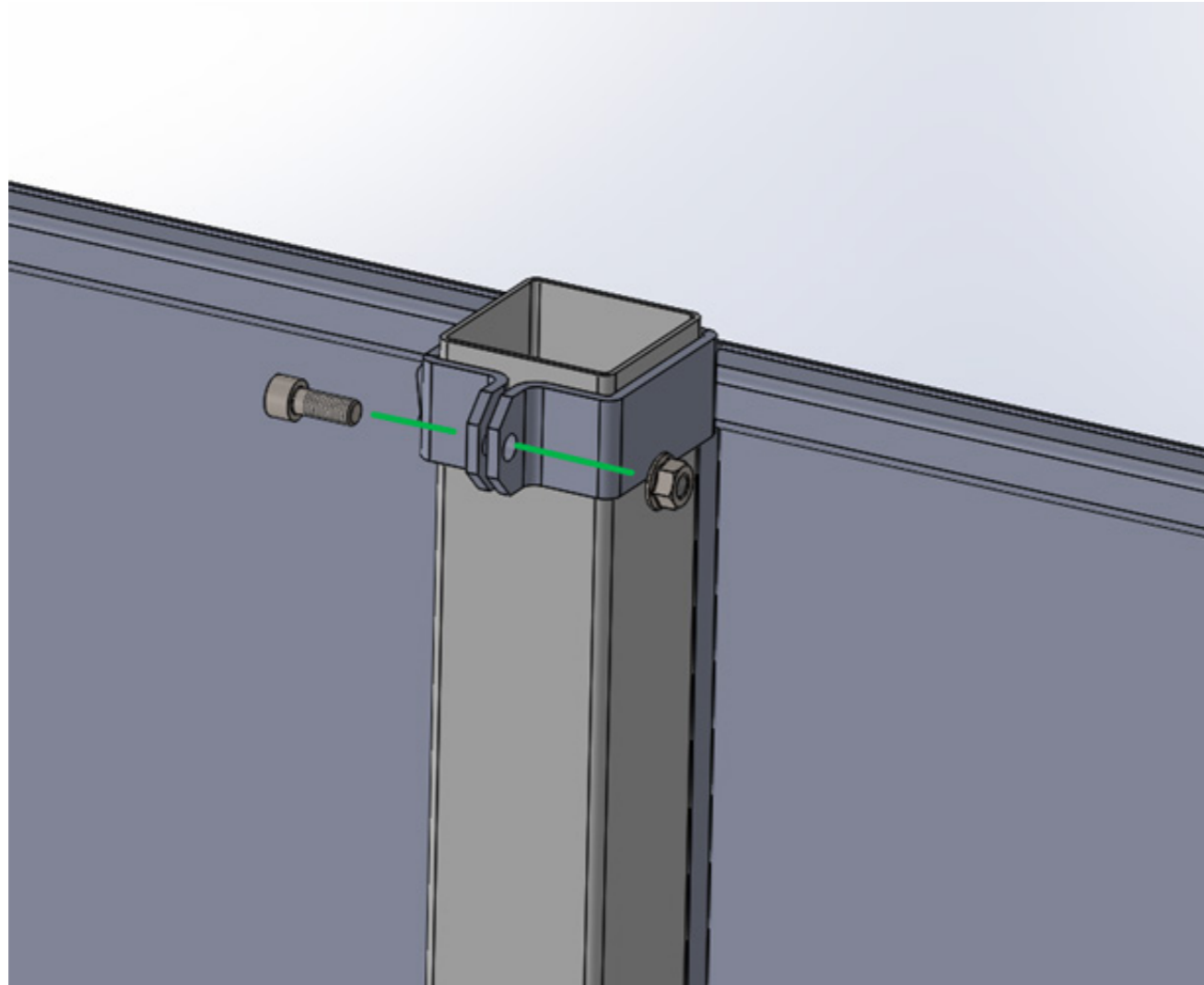

Once assembly of all panels is complete, proceed to tighten all top flanges using M8×20 Allen bolts and M8 nuts.

Check that each joint is correctly aligned and secured, ensuring the structural stability of the cabin.

x8: 11201-00277-Screw DIN912 M8×20
x8: 10503-00050-Nut DIN6923 M8

18- Right hinge cover

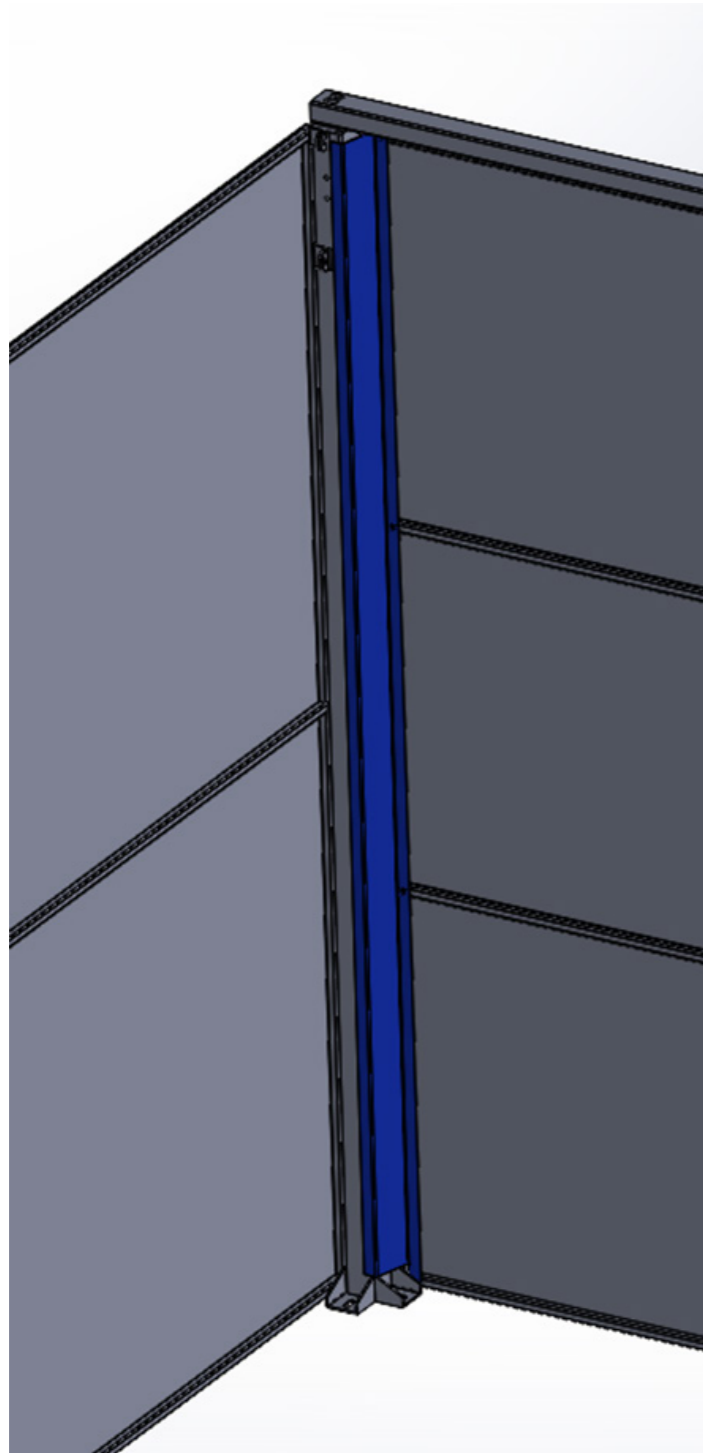

Right hinge cover

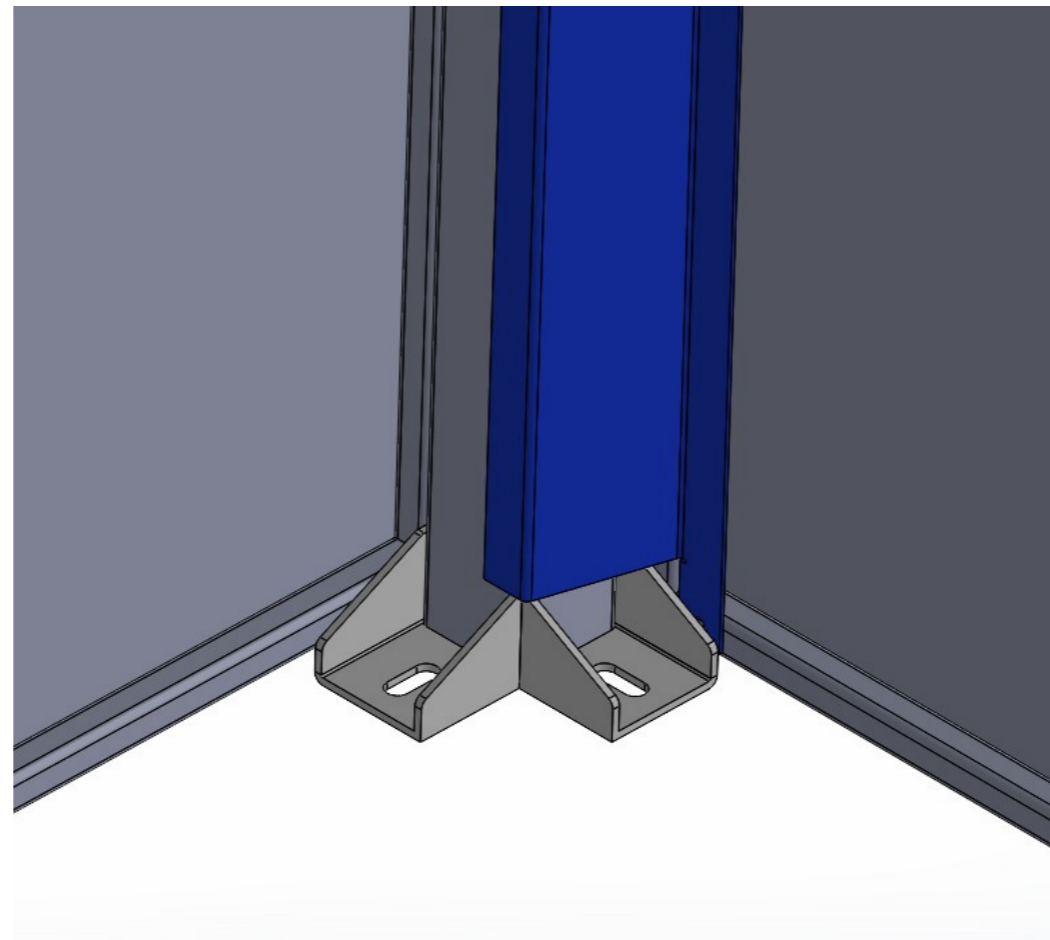

Place the right hinge cover on the corresponding door and secure it using four M5×10 screws.

Make sure that the cover is properly seated and that the screws are correctly tightened to avoid vibrations or displacement during use.

x1: 10502-00010_Right hinge cover
x4: 11201-00042_Screw DIN912 M5×10

19- Left hinge cover

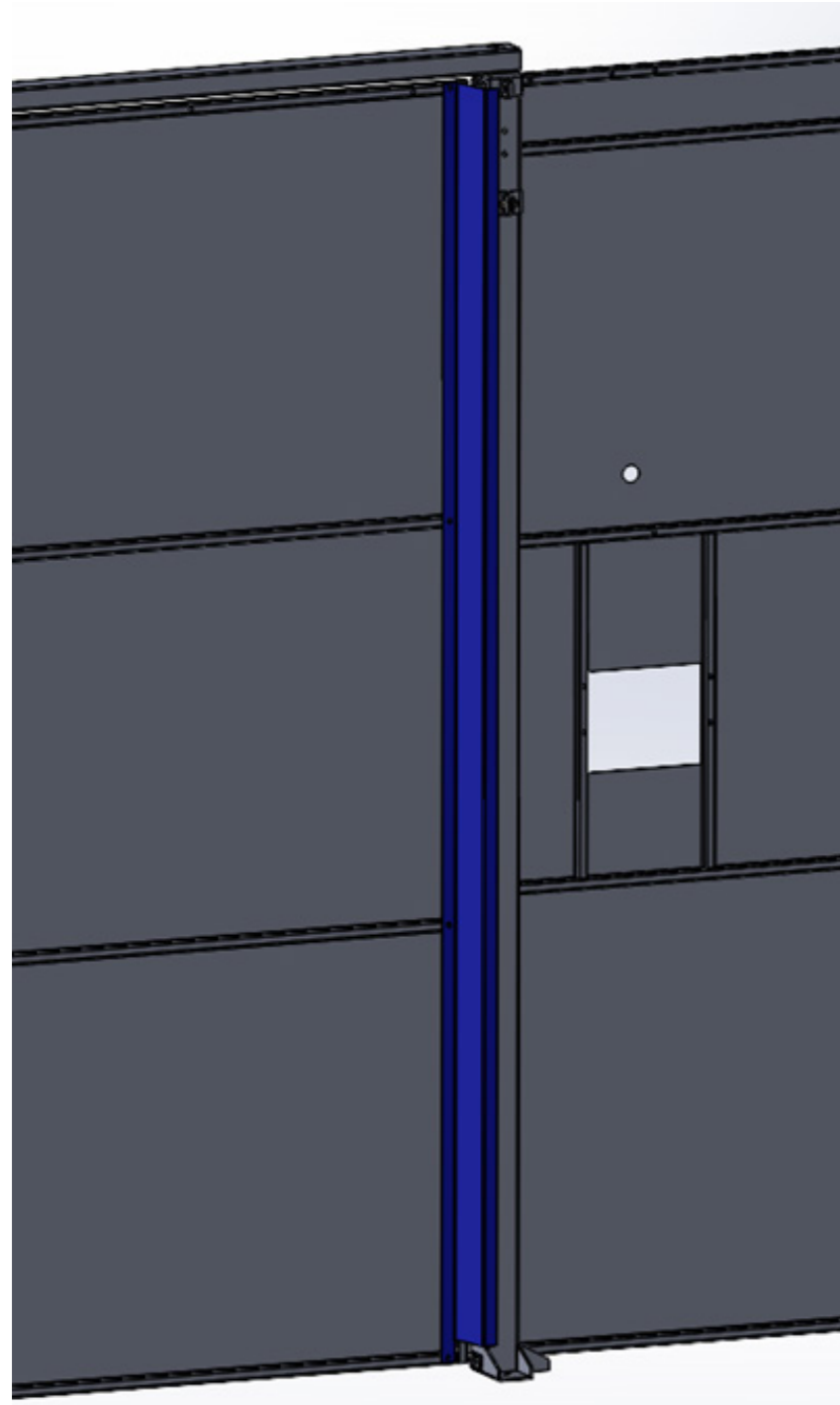

Left hinge cover

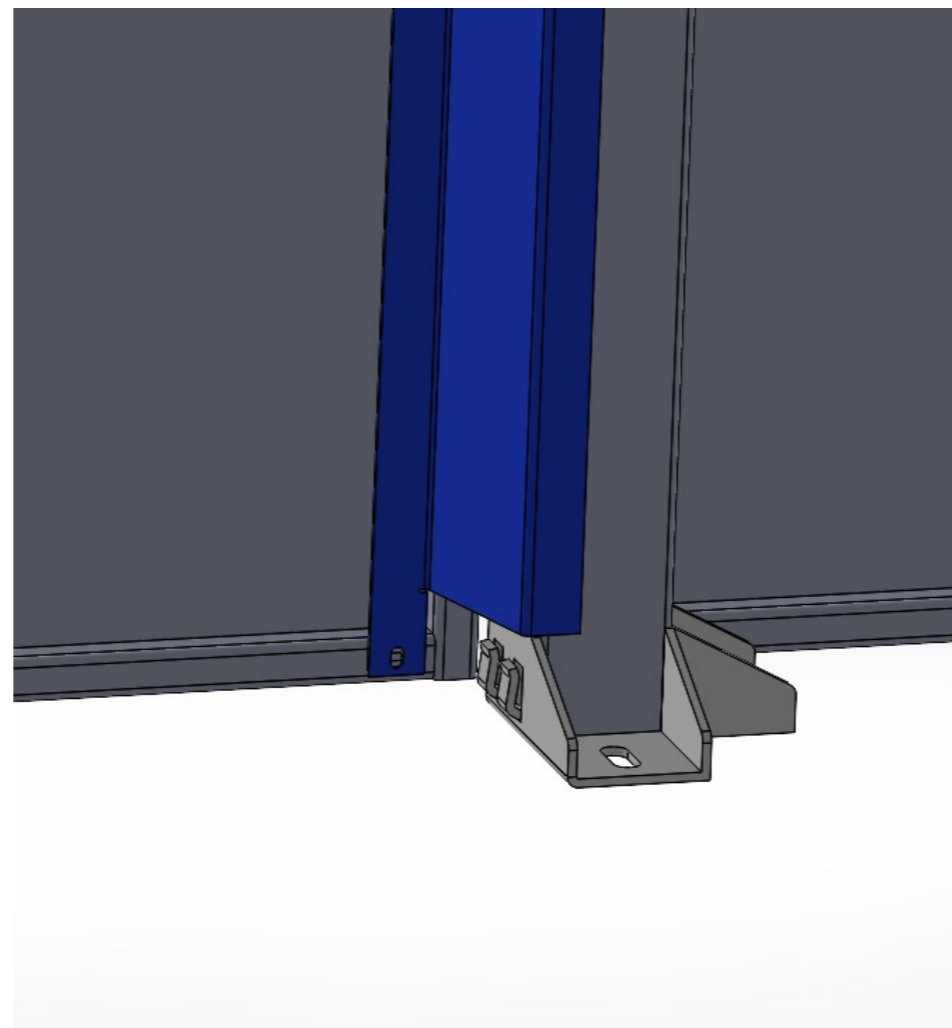

Place the left hinge cover over the left door and secure it with four M5×10 screws.

Check that the cover is correctly aligned and securely fastened to ensure a clean and safe finish.

x1: 10502-00011_Left hinge cover
x4: 11201-00042_Screw DIN912 M5×10

20- Central door cover

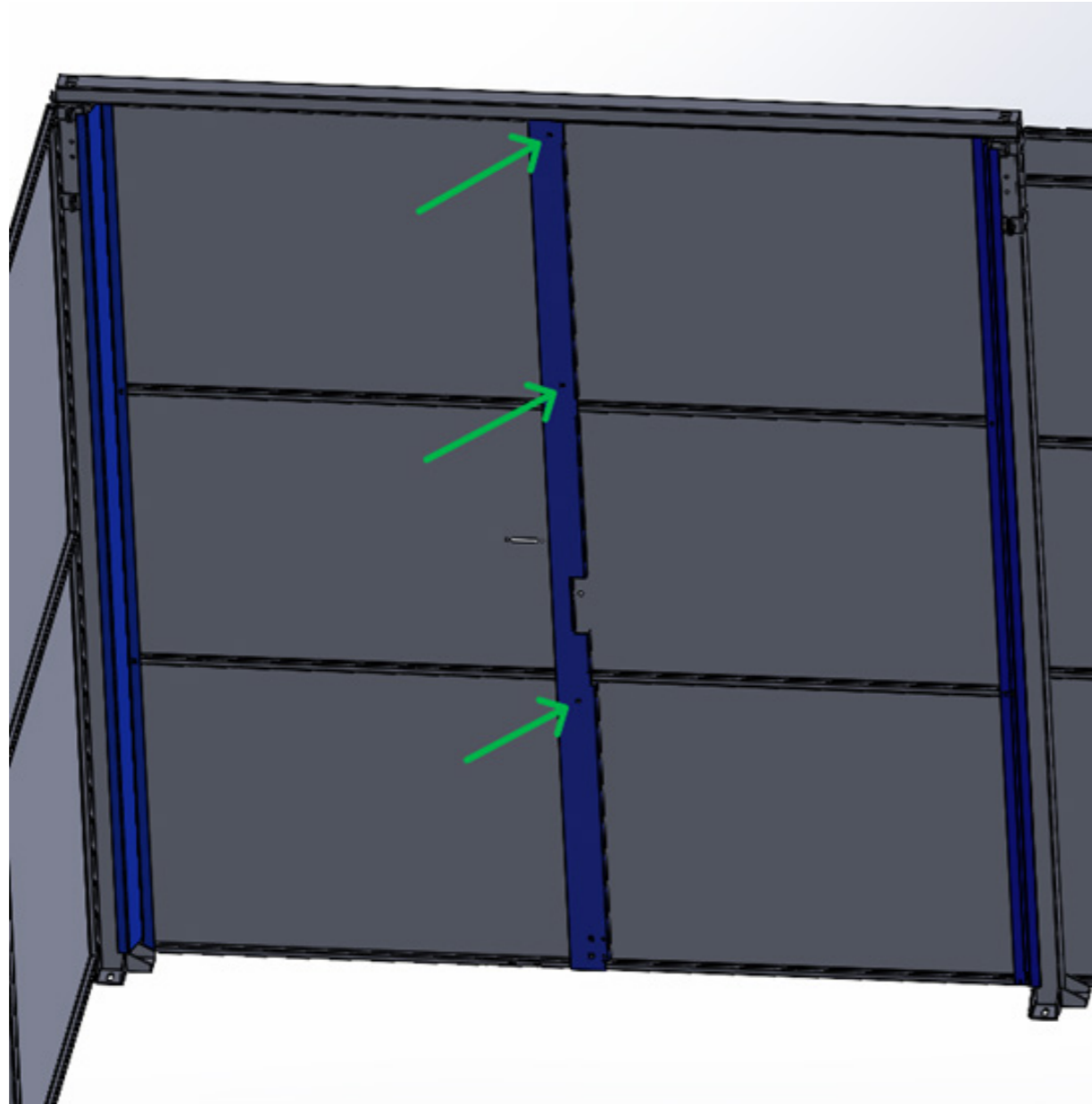

Place the centre cover in its corresponding position, securing it only with the top three M5×10 screws, as shown in the reference picture.

IMPORTANT:
Before carrying out this step, mount the door lock following the instructions in the section 'ASSEMBLY CLOSING'.

x1: 10502-00012_Central door cover
x3: 11201-00042_Screw DIN912 M5×10

21- Foot of the door

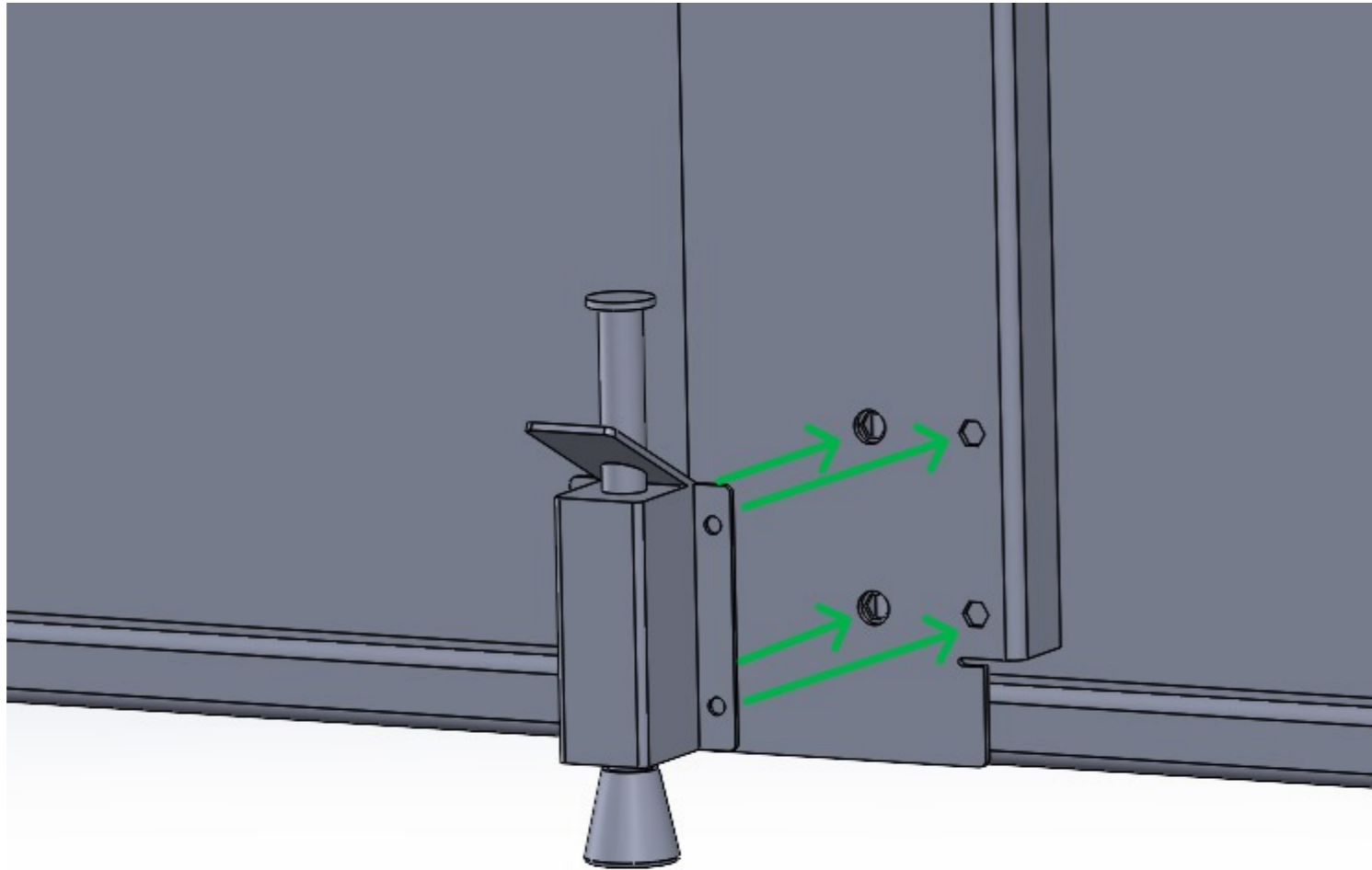

1. Install the door foot on the lower part of the structure, over the previously fitted central cover.

2. Secure the piece using four M4×8 screws, making sure that it is correctly aligned and firmly fastened to ensure proper closing and stability of the door.

IMPORTANT:

Before carrying out this step, mount the door lock following the instructions in the section 'ASSEMBLY CLOSING'.

- x1: 10502-00021_Foot stop bracket for door
- x4: 11201-00075_Screw DIN 912 M4×8

22- Magnets on door frames

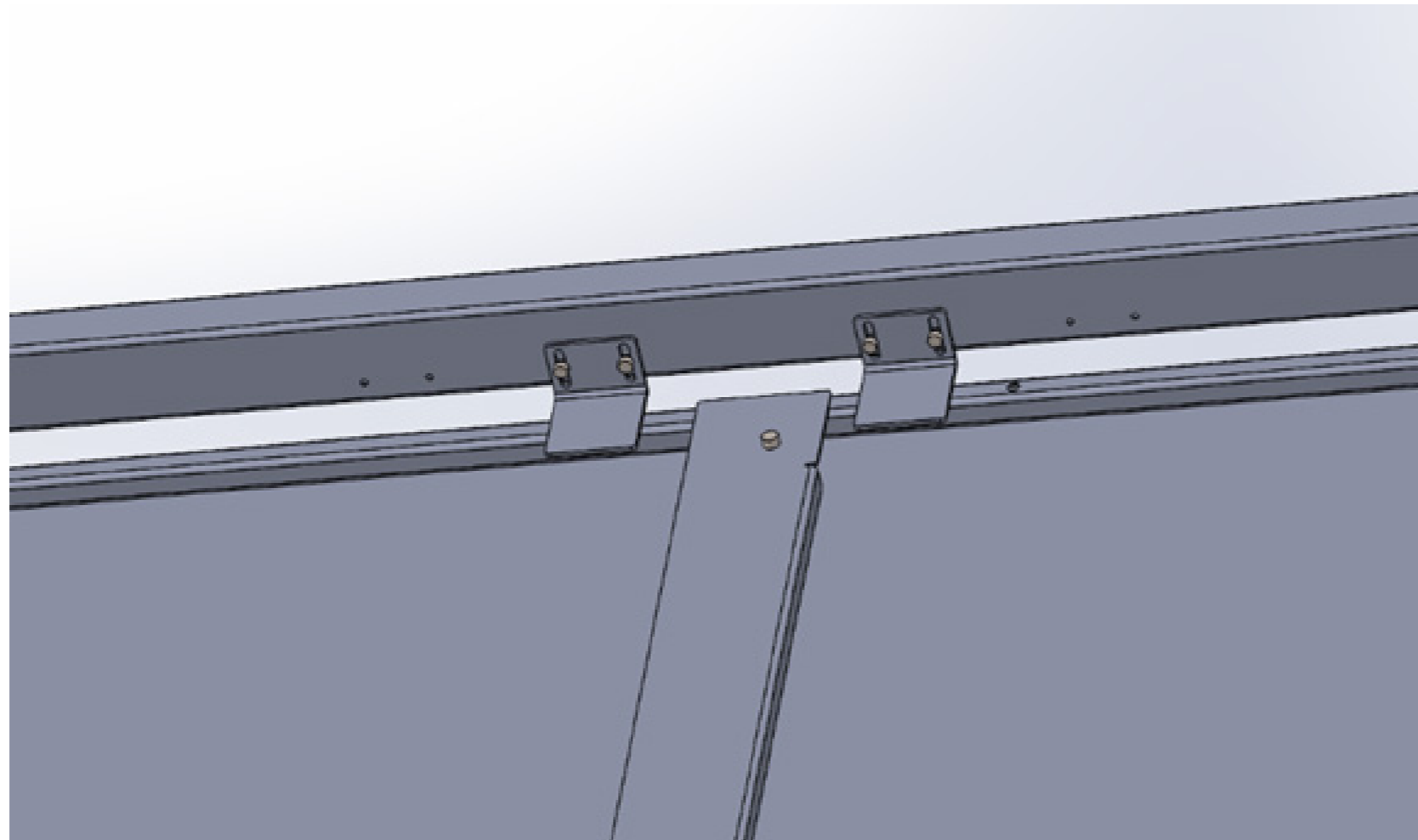

1. Attach the magnets to the frames of both doors using M4×8 screws, ensuring correct alignment to guarantee effective magnetic closure.

2. Next, install the locking brackets on the upper cross member according to the arrangement shown in the reference image, using M5×16 screws. Check that both the magnets and angles are securely fastened and correctly positioned to allow smooth and secure closing of both leaves.

x2: 10502-00013_Angle door magnet support
x2: 10502-00022_Magnetic door magnet
x4: 11201-00185_Screw DIN7380 M5×16
x4: 11201-00075_Screw DIN 912 M4×8

23- Cable glands

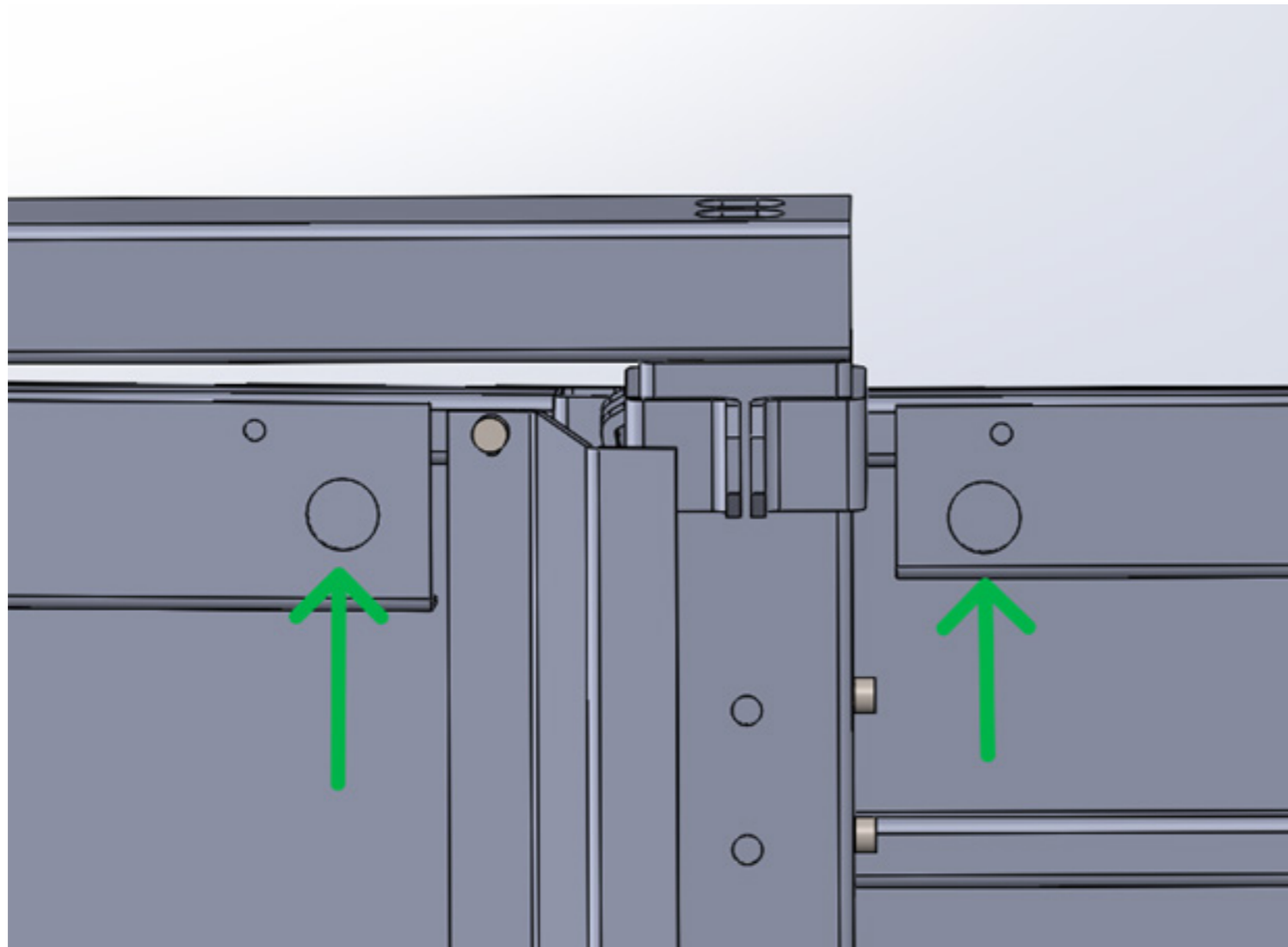

Install the two cable glands in the cable ducts, in the holes designated for this purpose.

These components will allow safe passage of the electrical wiring during assembly of the optional Lockdoor kit, ensuring mechanical protection and a professional finish to the cable routing.

x2: 10203-00015_ Cable gland M13.5

24- Door cable duct

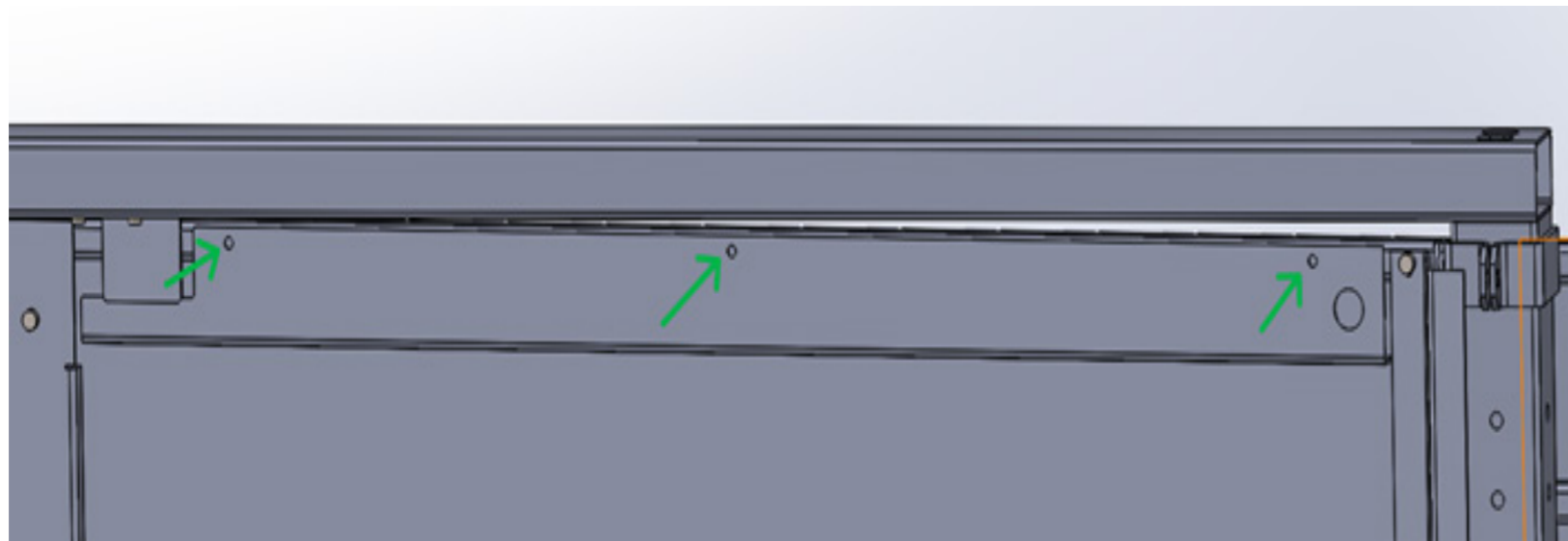

Secure the upper cable duct to the upper frame of the left-hand door, using three M5×10 screws.

Ensure that the cable duct is correctly aligned with the edge of the frame and securely fastened, allowing the electrical wiring to pass through neatly and safely.

- x1: 10502-00014_ Door cable duct
- x3: 11201-00042_Screw DIN912 M5×10

25- Electrical panel cable ducts

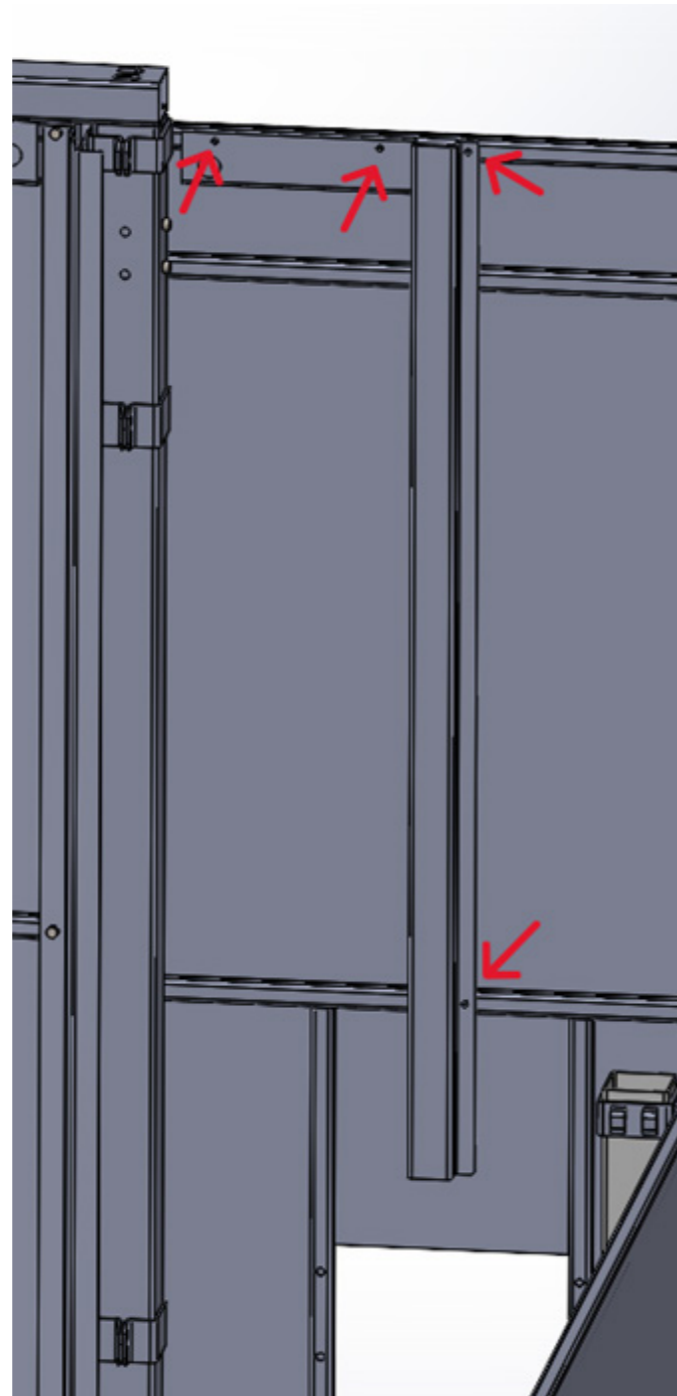

Fije las dos canaletas de cables correspondientes al cuadro eléctrico con cuatro tornillos M5, como se muestra en la imagen de referencia.

Asegúrese de que ambos conductos de cables están correctamente alineados y firmemente sujetos, permitiendo que el cableado interno se tienda de forma segura y ordenada.

x1: 10501-00016_ Panel eléctrico del conducto de cables
x1: 10501-00017_ Panel eléctrico del conducto superior
x4: 11201-00042_ Tornillo DIN912 M5×10



LC-CABIN V2









ASSEMBLY MANUAL

ASSEMBLY CLOSING

Screws









Closing

Image	Reference	Concept
	11201-00205	Screw DIN912 M6×50
	11201-00198	Screw DIN912 M6×20
	11201-00030	Self-locking Nut DIN985 M6
	11201-00244	Washer DIN125 M3
	11201-00210	Screw DIN933 M8×12
	11201-00277	Screw DIN912 M8×20
	11201-00214	Nut DIN934 M3
	11201-00230	Screw DIN912 M3×10
	11201-00233	Screw DIN912 M3×8

Screws











With Lockdoor

Image	Reference	Concept
	11201-00191	Screw DIN912 M5×40
	11201-00163	Screw 3×30
	11201-00150	Screw DIN912 M6×10
	11201-00315	Screw M4×16 ISO7380
	11201-00045	Nut DIN934 M4
	10601-00041	Washer DIN125 M5

Screws



Without Lockdoor



Image	Reference	Concept
	11201-00130	Screw DIN912 M3×16
	11201-00198	Screw DIN912 M6×20
	11201-00030	Self-locking Nut DIN985 M6
	11201-00244	Washer DIN125 M3
	11201-00075	Screw DIN912 M4×8
	11201-00214	Nut DIN934 M3
	11201-00128	Screw DIN912 M3×12
	10601-00040	Washer DIN125 MG
	11201-00185	Screw DIN7380 M5×16





Parts breakdown

* Breakdown for all cab variations. All orders for LC-CABIN V2 do not carry all parts listed below.

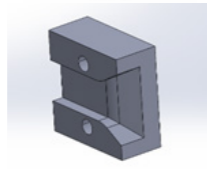
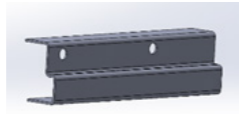
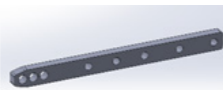

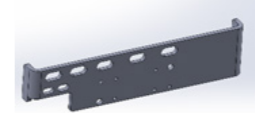
CABIN V2 Closing Kit

Name	Piece	Reference
Lockdoor cover angle		10110-00013
Lockdoor base plate		10110-00016
Lockdoor latch centering piece		10110-00017
Lock cover		10110-00018
Door latch bolt		10110-00019

Name	Piece	Reference
Linear Guide Lock Adapter		10110-00020
Interior Lock Component		10110-00021
Handle B224117.0010		10110-00024
Linear Guide MGN12C		10110-00025

Parts breakdown

* Breakdown for all cab variations. All orders for LC-CABIN V2 do not carry all parts listed below.



Set with Lockdoor CABIN V2

Name	Piece	Reference
Allen safety unlock		10110-00014
Ring safety unlock		10110-00015
Bracket for locking system		10110-00022
Bernstein safety lock switch		10110-00023
Safety lock trigger		10110-00026
Lockdoor V2 Extever cable		10401-00290
Metal cable gland M20		10601-00072
Cable gland PG7		10203-00022

Set without Lockdoor CABIN V2

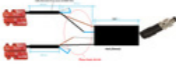
Name	Piece	Reference
Cab door angle sensor V2		10502-00024
Door sensor		10199-00002

1- Mount the latch base

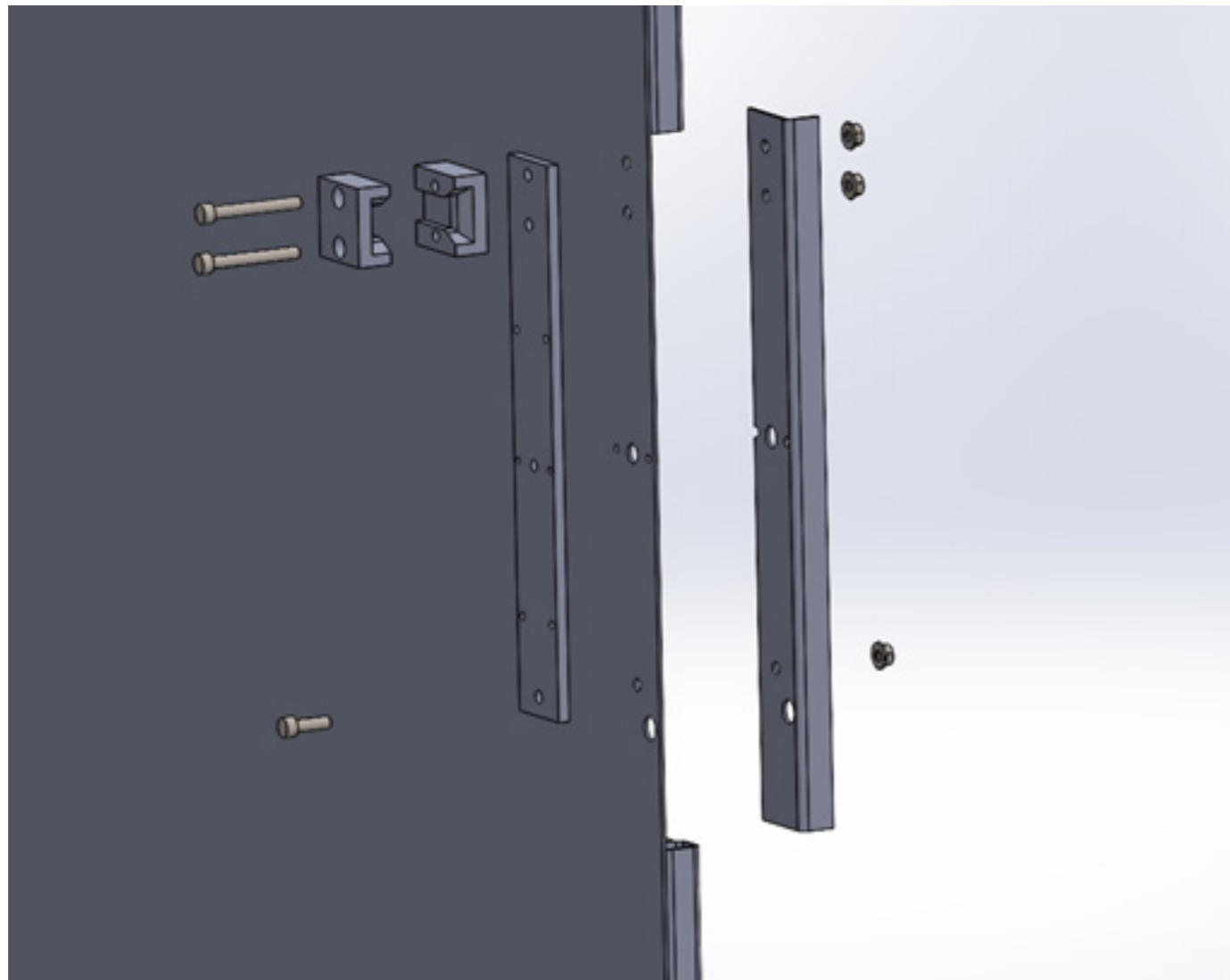

The first step will be to mount the lockdoor base on the left door.

Attach the alignment guides by going through the lockdoor base, the door panel, and the bracket, using two M6×50 screws, one M6×20 screw, M6 washers, and M6 nuts.

- x2: 10110-00017_ lockdoor alignment guide
- x1: 10110-00016_ lockdoor base bracket
- x1: 10110-00013_ lockdoor top angle
- x2: 11201-00205_ DIN912 screw M6×50
- x1: 11201-00198_ DIN912 screw M6×20
- x3: 11201-00030_ self-locking nut DIN 985 M6
- x3: 10601-00040_ washer DIN125 M6

2- Place the safety interlock switch (only lockdoor version)

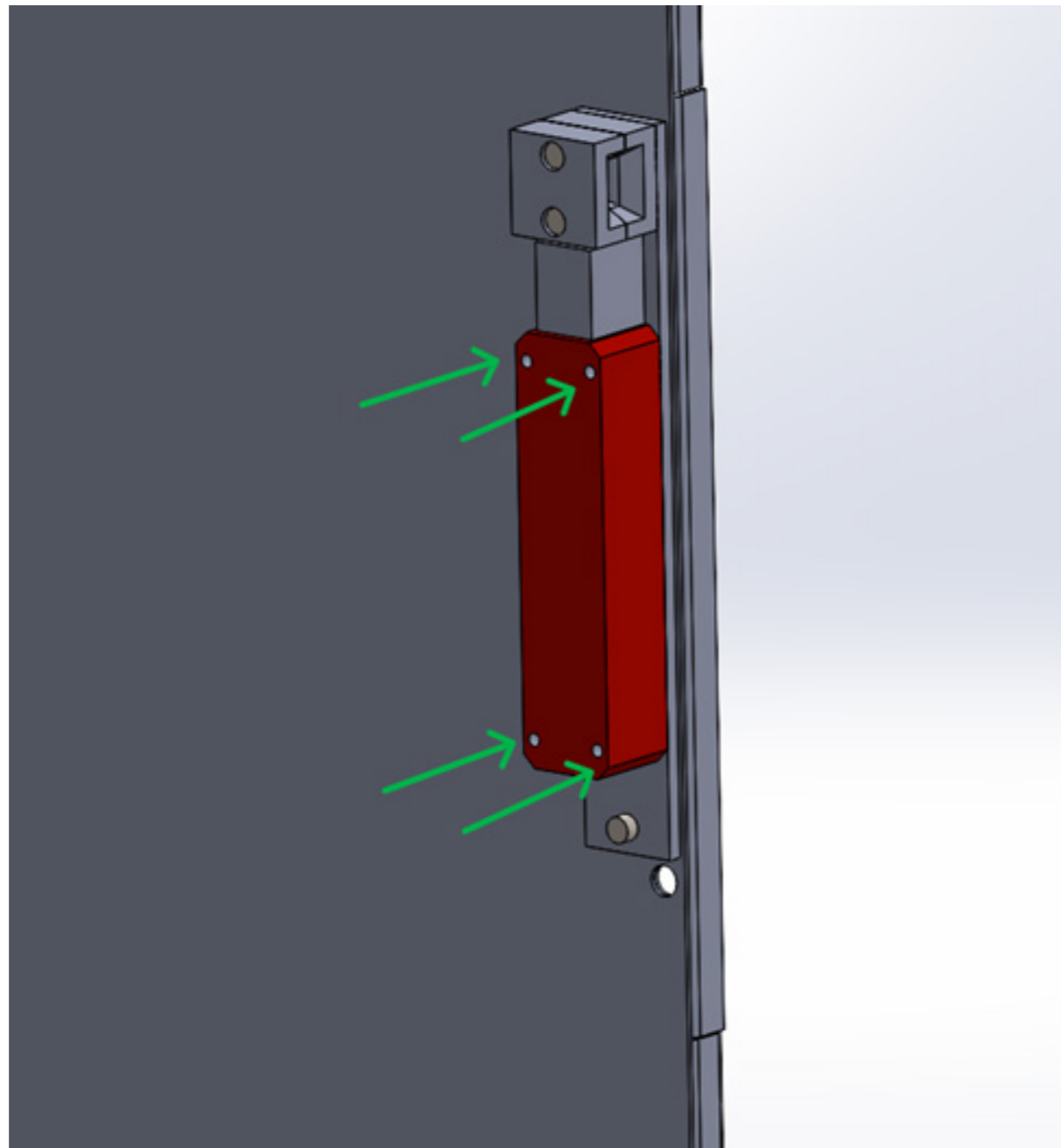

Place the Bernstein safety switch on the base plate and fix it with four M5×40 screws.

x1: 10110-00023_Bernstein safety lock switch
x4: 11201-00191- Screw DIN912 M5×40

3- Fit unlocking system (only lockdoor version)



Fix the safety unlocking system using two self-tapping screws. Place the allen safety unlock with the slot facing upward.

Place the ring with the graphic facing upward, as shown in the image.

x2: 11201-00163_ screw 3×30
x1: 10110-00015_ ring safety unlock
x1: 10110-00014_ allen safety unlock

4- Mount rail and linear guides



Fix the rail and linear guides to the right door using M3×12 screws and M3 nuts. Ensure precise alignment to guarantee smooth sliding of the mechanism.

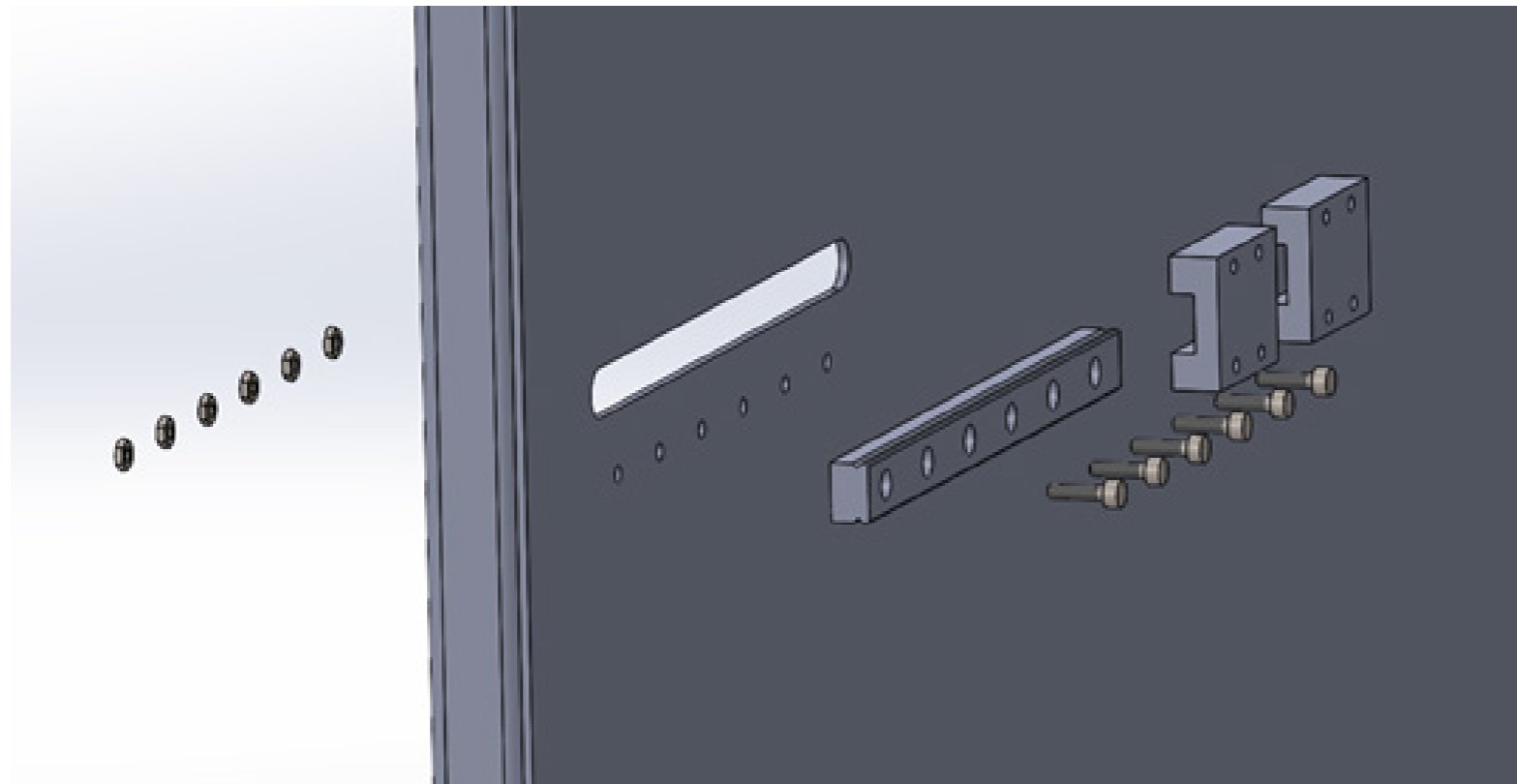

- x1: 10110-00025_ linear guide MGN12C
- x6: 11201-00230_ screw DIN 912 M3×10
- x6: 11201-00214_ nut DIN 934 M3

5- Place the inner plate

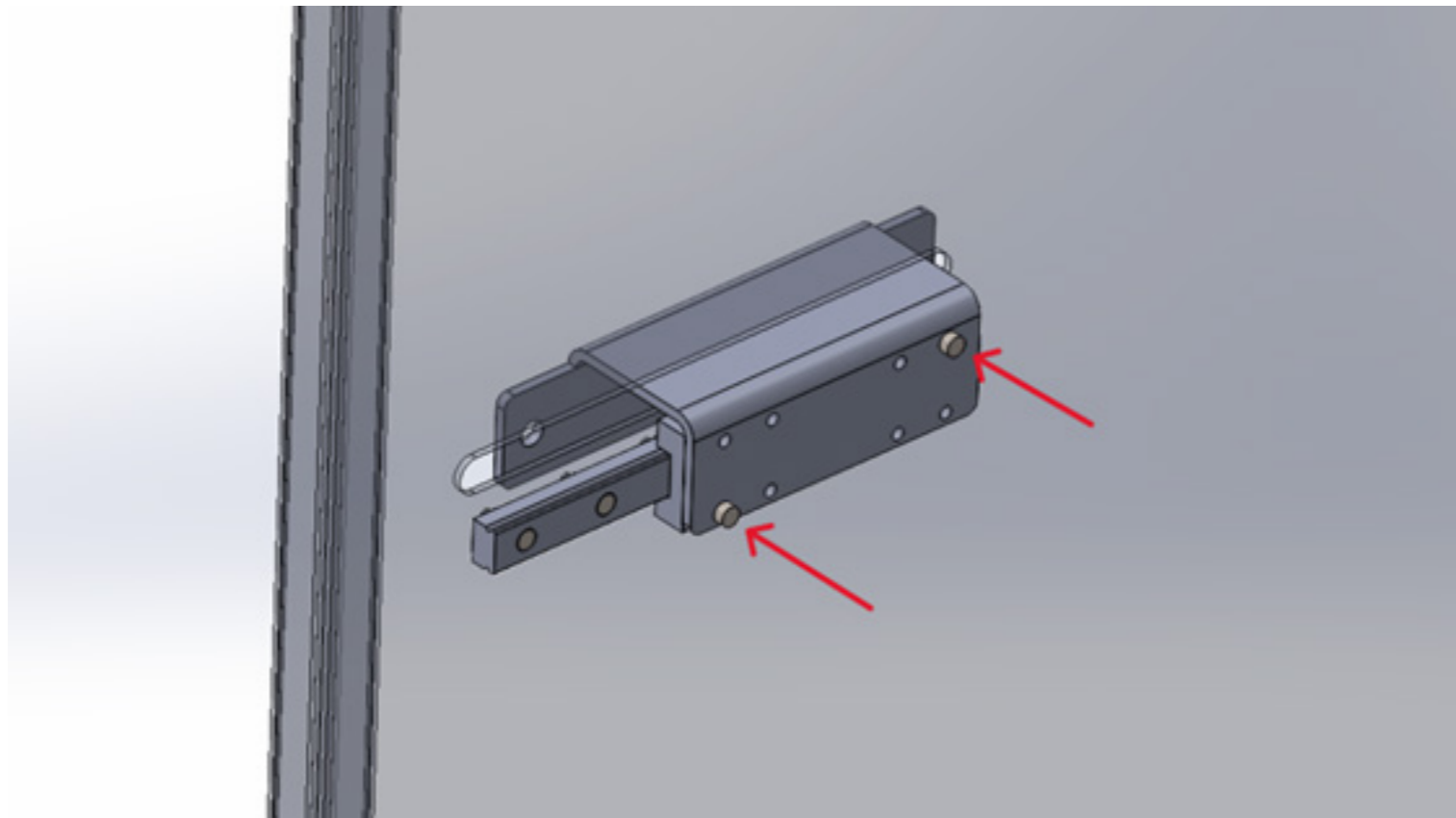

Place the inner plate using only two screws in the corners, as shown in the reference image.

For this step, use the shortest screws (M3×8).

x1: 10110-00021_ inner lock part
x2: 11201-00233_ screw DIN 912 M3×8

6- Screw the bolt

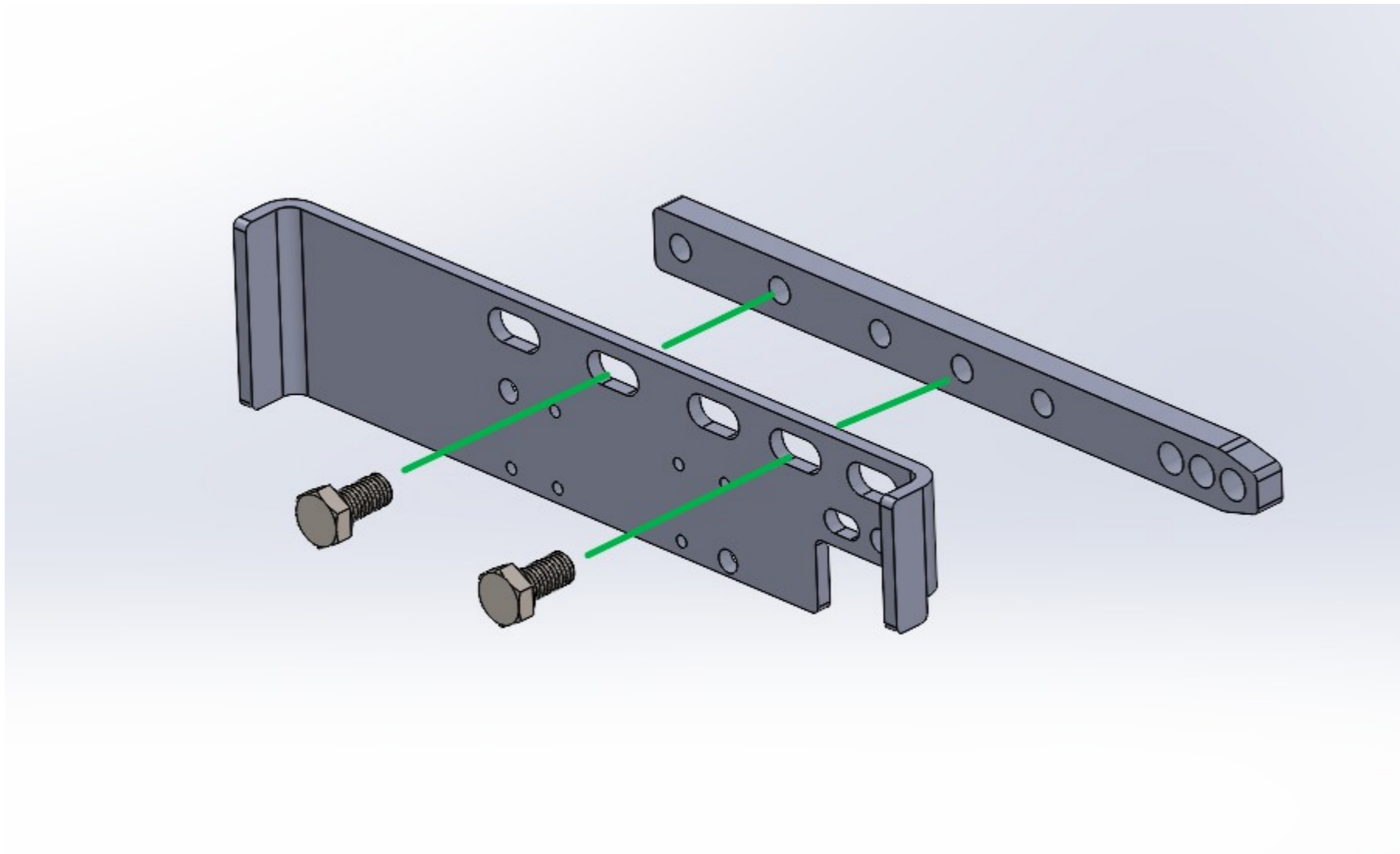

Screw the bolt to the adapter plate using two M8×12 screws. Make sure the bolt is securely fastened and properly aligned with the mechanism.

x1: 10110-00019_ door lock bolt
x1: 10110-00020_ lock adapter with linear guide
x2: 11201-00210_ screw DIN933 M8×12

7- Mount the adapter plate

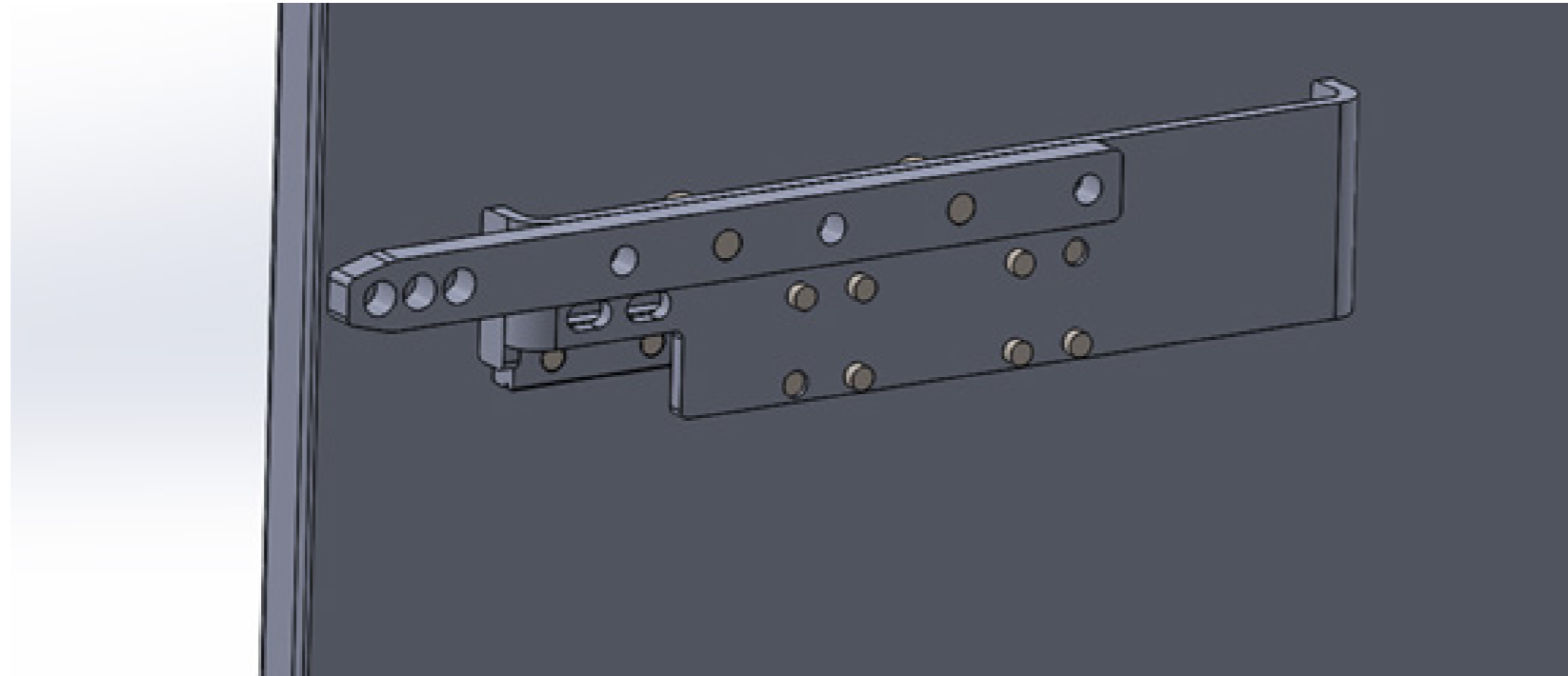

Attach the adapter plate to the linear guide using the remaining six M3×10 screws.

x6: 11201-00230_ screw DIN 912 M3×10

8- Mount the angle to the adapter plate and the locking trigger (only lockdoor version)

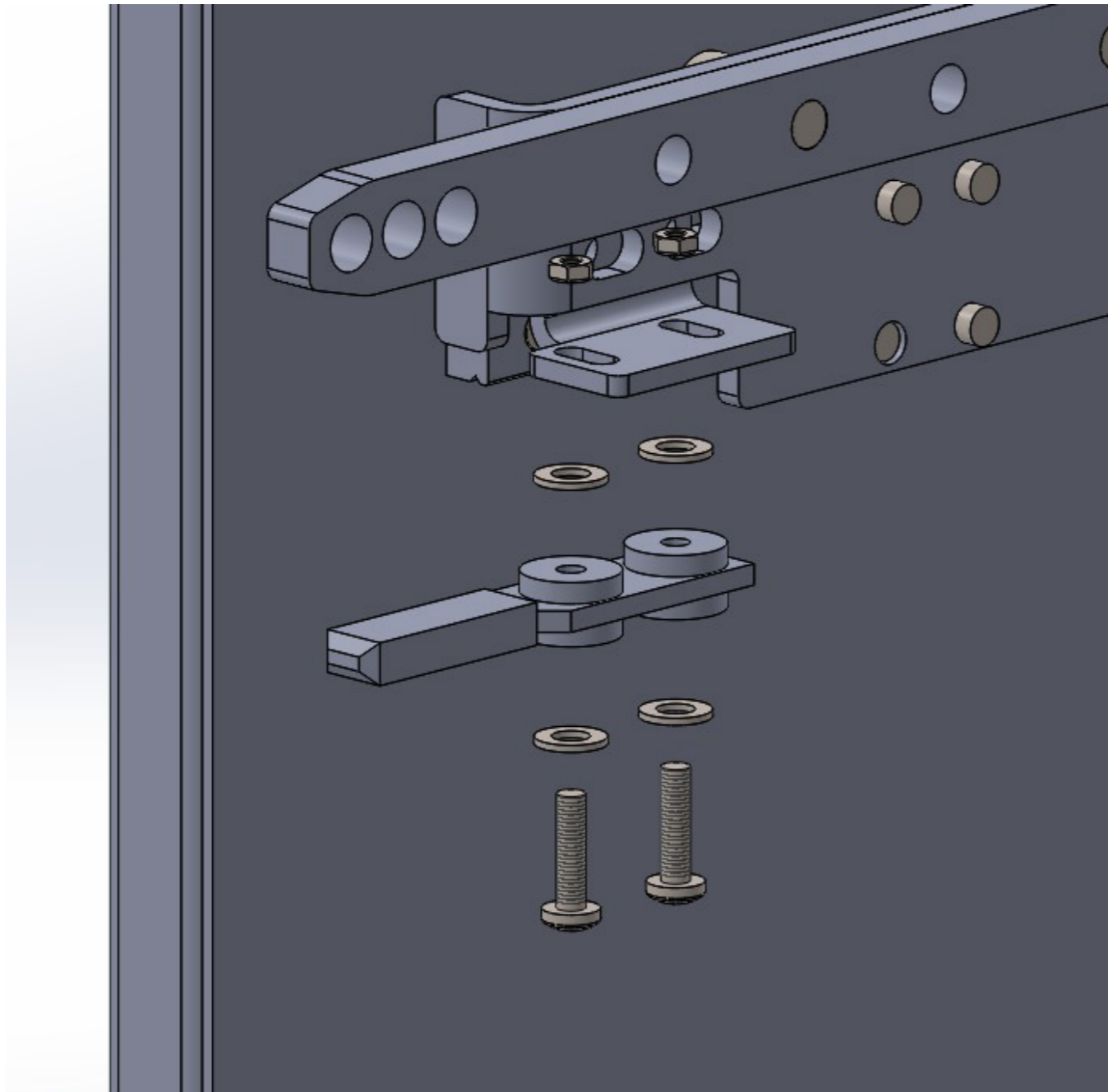

Secure the angle to the adapter plate using two M6×10 screws.

Then, install the locking trigger using M4×16 screws, along with washers and nuts, as shown in the illustration.

Ensure both components are properly fastened to guarantee the safe operation of the system.

- x1: 10110-00022 – Locking system angle
- x1: 10110-00026 – Safety locking trigger
- x2: 11201-00150 – DIN912 M6×10 screw
- x2: 11201-00315 – ISO7380 M4×16 screw
- x2: 11201-00045 – DIN934 M4 nut
- x4: 10601-00041 – DIN125 M5 washer

9- Adjust the lock (only lockdoor version)

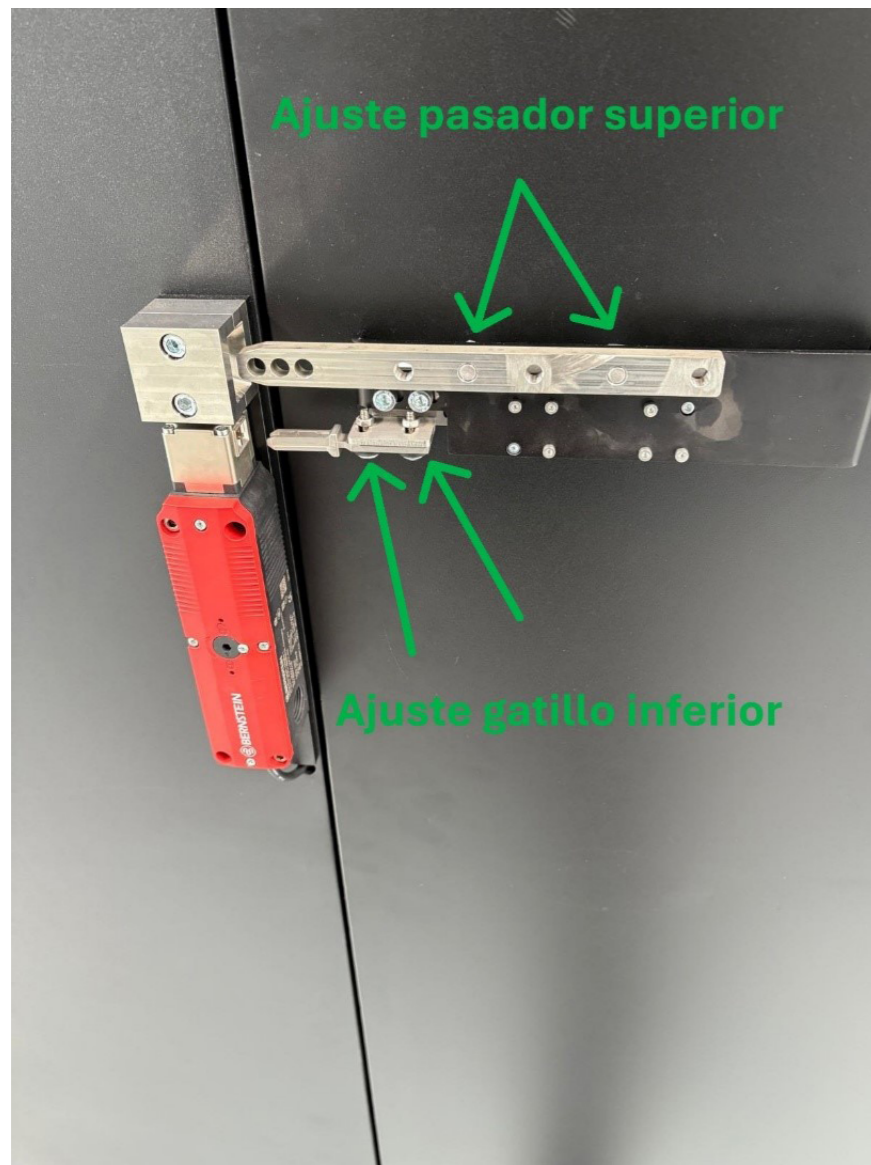

Move the handle to close the door. Adjust the position of the upper bolt using the hex screws to ensure proper alignment with the centering block (the upper bolt should be slightly forward in relation to the centering piece).

Once the upper bolt is correctly aligned, adjust the position of the locking trigger so that it can properly engage with the safety lock.

10– Screw the handle to the latch

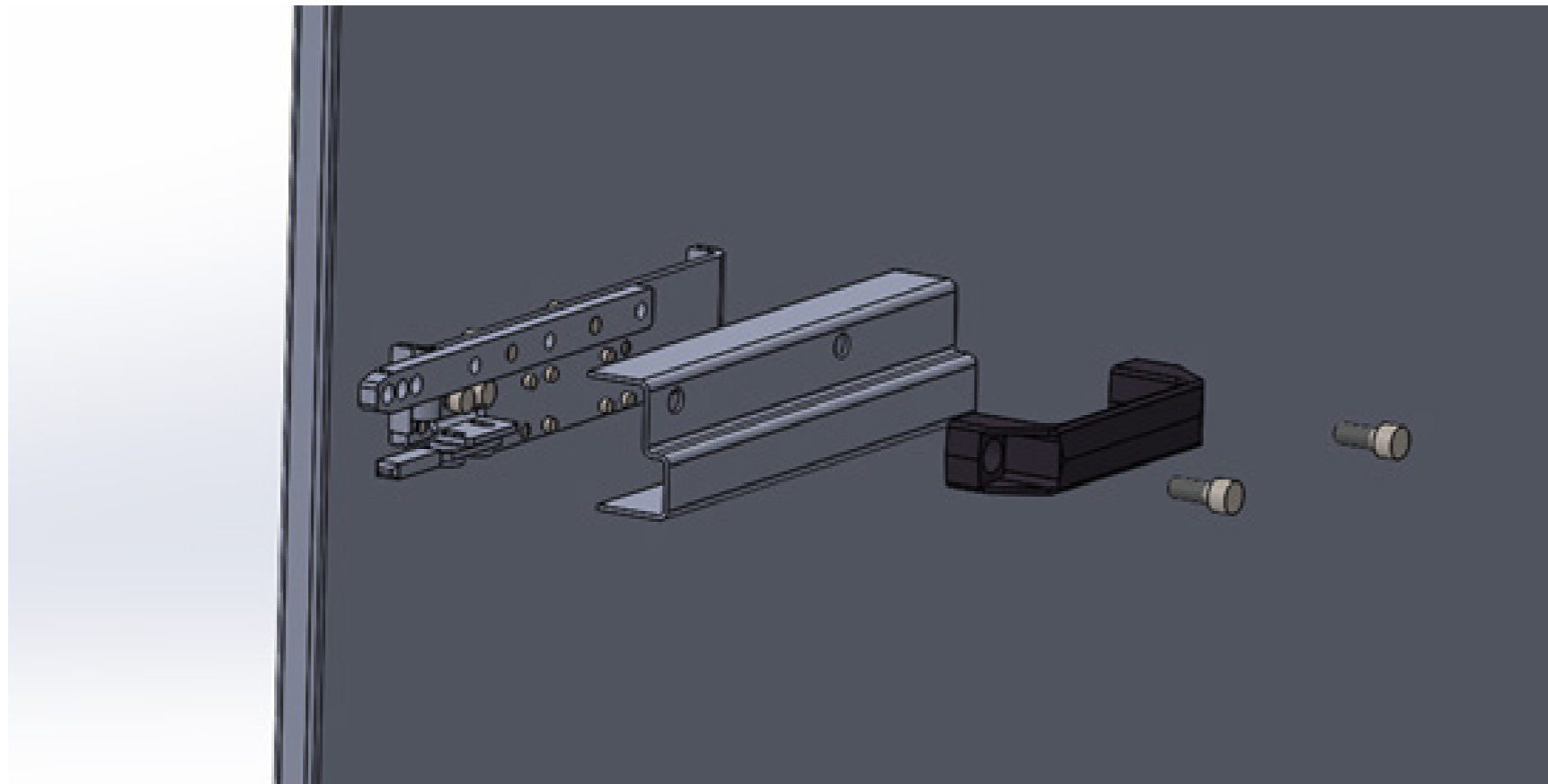

Screw the handle to the latch along with the lock cover, using M8×20 screws.

Ensure both components are firmly secured and properly aligned for optimal operation of the locking mechanism.

x1: 10110-00018 – Lock cover
x1: 10110-00024 – Handle B224117.0010
x2: 11201-00277 – Screw DIN912 M8×20

11 - Install the interior handle

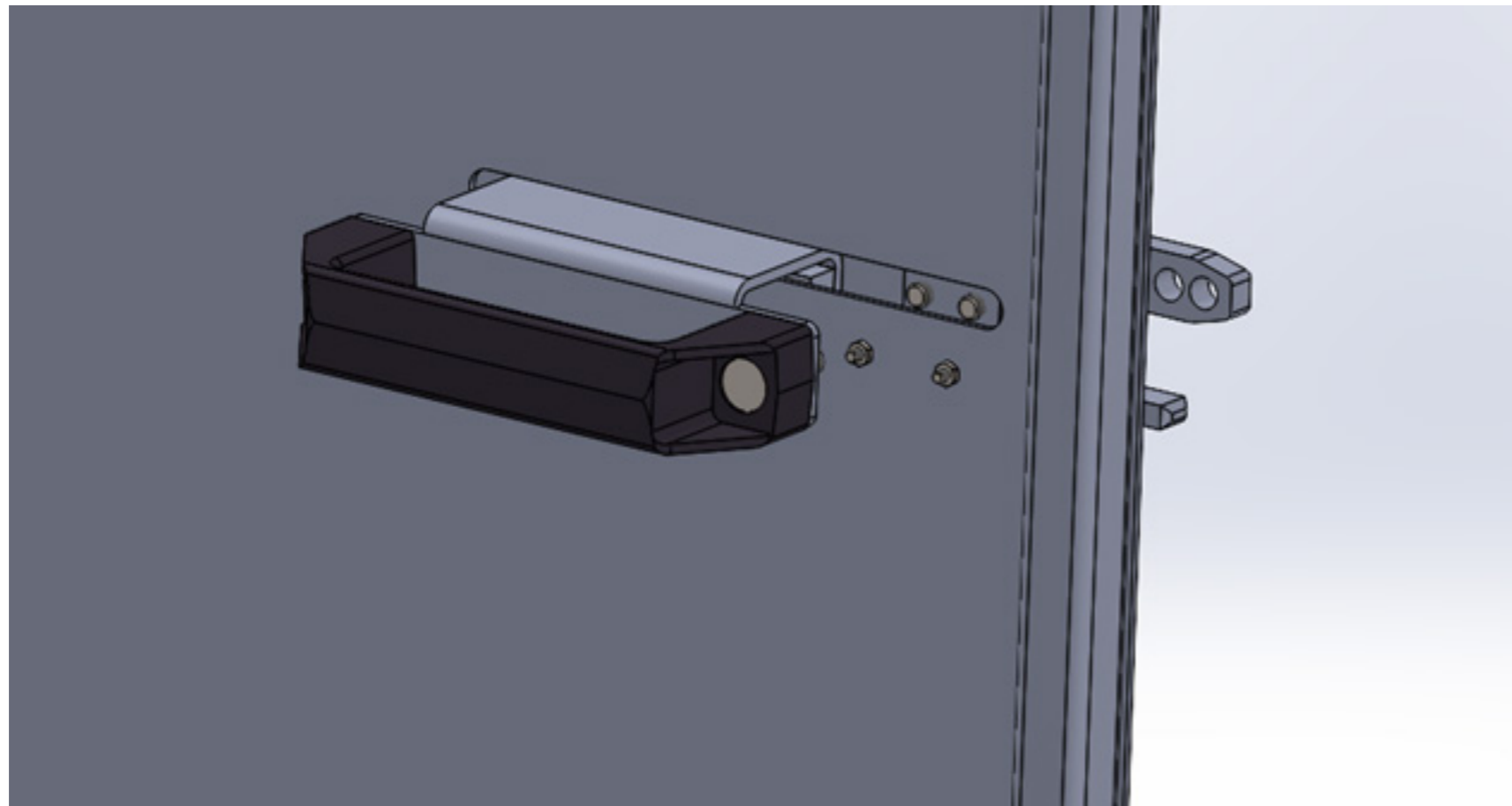

Secure the interior handle using two M8×20 screws. Ensure that the handle is properly aligned and that it operates smoothly without any obstructions.

x1: 10110-00024 – Handle B224117.0010
x2: 11201-00277 – Allen screw DIN912
M8×20

12 – Insert the screws into the base plate (only without lockdoor)



Screw in the two M3 screws and the M6 screw along with their respective washers and nuts into the middle holes of the base plate.

x1: 11201-00198 – Screw M6×20
x1: 10601-00040 – Washer M6
x1: 11201-00030 – Self-locking nut M6
x2: 11201-00130 – Screw M3×16
x2: 11201-00244 – Washer M3
x2: 11201-00214 – Nut M3

13 – Installing the Door Sensors (only lockdoor version)



STEP 1

Screw the door sensor brackets to the upper crossbar using M5 screws.

Next, mount the two sensors without cable to the top of the door, and the two with cable to the angle bracket on the crossbar. Adjust their positions so that, when the door is closed, the sensors are as close together as possible.

- x1: 10199-00002 – Door sensor
- x2: 10502-00024 – Door sensor bracket, cabina v2
- x8: 11201-00128 – Screw M3×12
- x4: 11201-00214 – Nut M3
- x4: 11201-00185 – Screw DIN7380 M5×16

13 – Installing the Door Sensors (only without lockdoor version)



STEP 2:

Insert the sensor cable through the upper hole in the door's crossbar and route it inside, through the cable ducts of the electrical panel, up to the cabin's control box. Connect the cable to the box.

ANNEX – SAFETY CONTROL WITH ACCESS LOCK



Operating Logic

Operating Conditions:

- The cabin control is connected to the welding machine
- The door sensors are properly aligned when the door is closed.
- The laser welding machine is active.

Access Sequence:

1. The access door is locked by default when the door is closed.
2. It is recommended to press the audible alert button to notify possible access to the operator inside the cabin. Button No. 5
3. To enter the cabin, it is necessary to press button No. 6.
4. The safety control immediately disables laser emission via the Interlock signal.
5. A 3-second delay begins for the unlocking of the cabin door. During this time, indicator light No. 7 flashes
6. After the 3 seconds, the door unlocks, allowing access, and the indicator light changes to a steady ON state.
7. The door locks again after 5 seconds. At this point, indicator No. 7 turns OFF and the interlock signal must be reset by pressing Reset button No. 4.
8. Indicator light No. 1 remains ON as long as the access door is closed and the system is correctly reset.

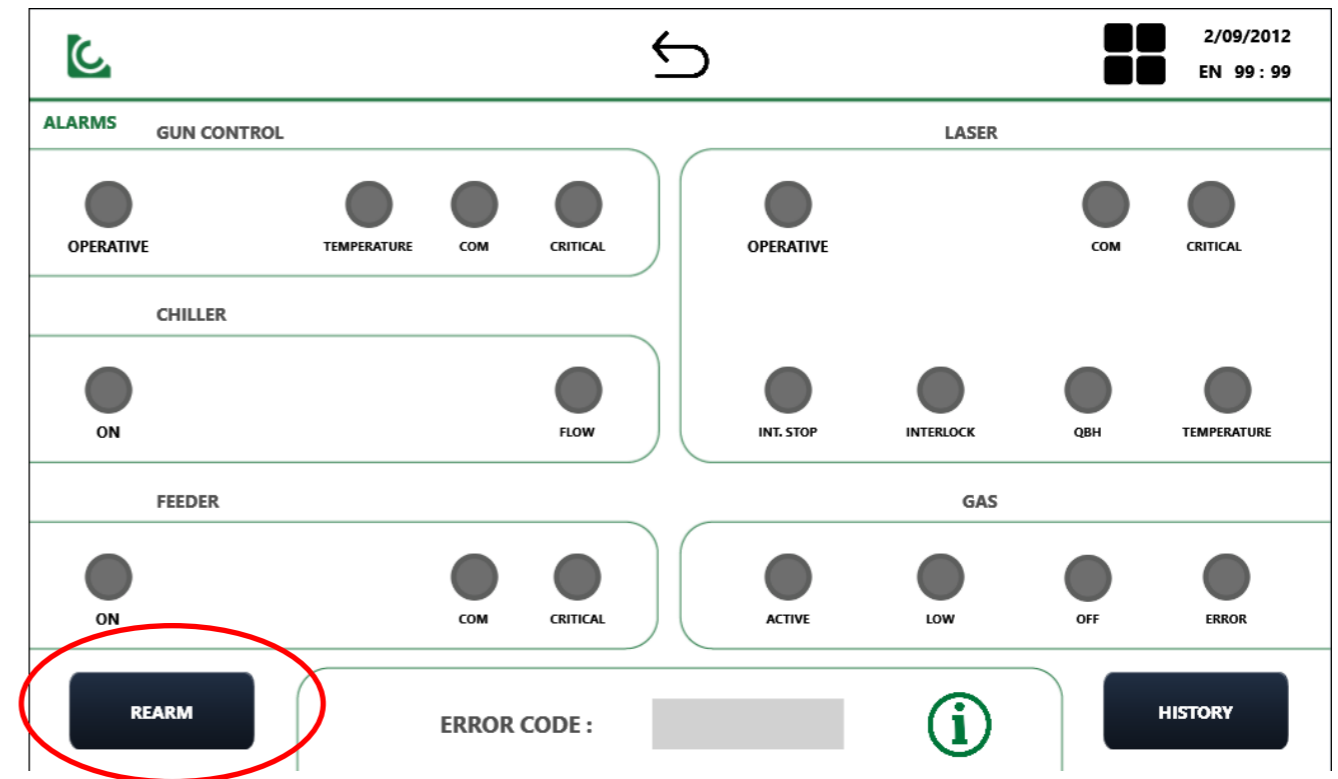

* If access is attempted (Interlock signal deactivated) while the welding machine is emitting the laser, or if done from the welding screen, the Interlock alarm will be triggered and appear on the screen. To reactivate the machine, the “REARM” button must be pressed from the alarm screen.

** If the welding machine is turned off, the door remains unlocked in “Fail Safe” mode.

Possible Failures:

. The green indicator light (1) does not stay ON. It only activates when the REARM button (4) is pressed.

- a. Ensure the door is closed and the door sensors are correctly aligned. This issue may be due to a door sensor failure.
- b. The machine must be ON and correctly connected to the cabin safety control system.

ANNEX – SAFETY CONTROL WITH ACCESS LOCK



Operating Logic

Operating Conditions:

- The cabin control is connected to the welding machine.
- The door sensors are properly aligned when the door is closed.
- The laser welding machine is active. Condiciones de funcionamiento:

Access Sequence:

1. The access door is locked by default when it is closed.
2. It is recommended to press the audible alert button to warn of potential access to an operator inside the cabin. (Button no. 5)
3. To access the cabin, button no. 6 must be pressed.
4. The safety control immediately disables the laser beam emission through the Interlock signal.
5. A 3-second delay begins to unlock the cabin door. During this time, the indicator light no. 7 blinks.
6. After 3 seconds, the door unlocks, allowing access, and the indicator light remains steadily on.
7. The door locks again after 5 seconds. At this point, indicator no. 7 turns off and the interlock signal can be reset using Reset button no. 4.
8. Indicator light no. 1 will remain lit as long as the access door is closed and the system has been properly reset.

* If access is attempted (Interlock signal deactivated) while the welding machine is still emitting the laser or from the welding screen, the Interlock alarm will appear on screen

To reactivate the machine, press the REARM button shown on the alarm screen.